

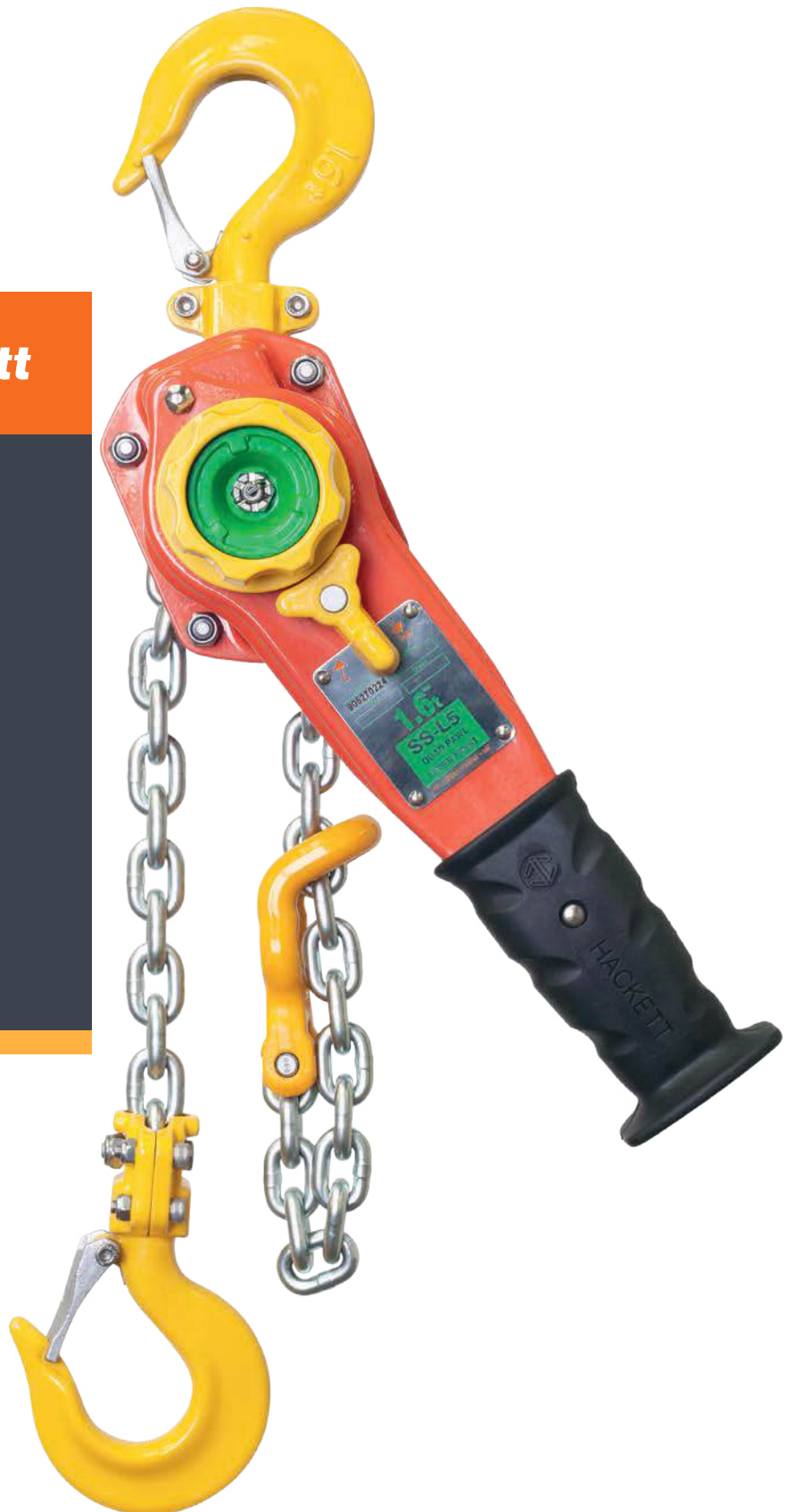

**William Hackett**

*SS-L5 QP  
Lever Hoist  
User Manual*





# Contents

1.	Dimensions and Specifications .....	4
2.	Hoist Selection .....	5
3.	Pre-use checks.....	6
4.	Hoist Operation .....	7
5.	Safe Use Information .....	8
6.	Immersion Policy, Procedures and Storage .....	9
7.	Practical Considerations .....	10-11
8.	Spare Parts Inspection Category .....	12
9.	Parts List .....	13
10.	Parts Explosion .....	14
11.	Hoist Disassembly .....	15
12.	Maintenance and Repair .....	16-26
13.	Assembly Instructions .....	27
14.	Brake Set-up .....	28-33
15.	Warranty .....	36
16.	DNV-GL Salt Water Immersion Testing Certificate .....	37
17.	Inspection Log .....	38

# Dimensions and Specifications

## Single Fall

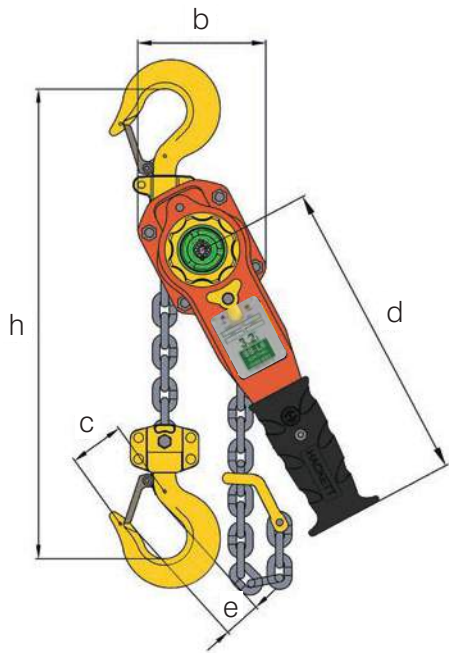

## Multi Fall

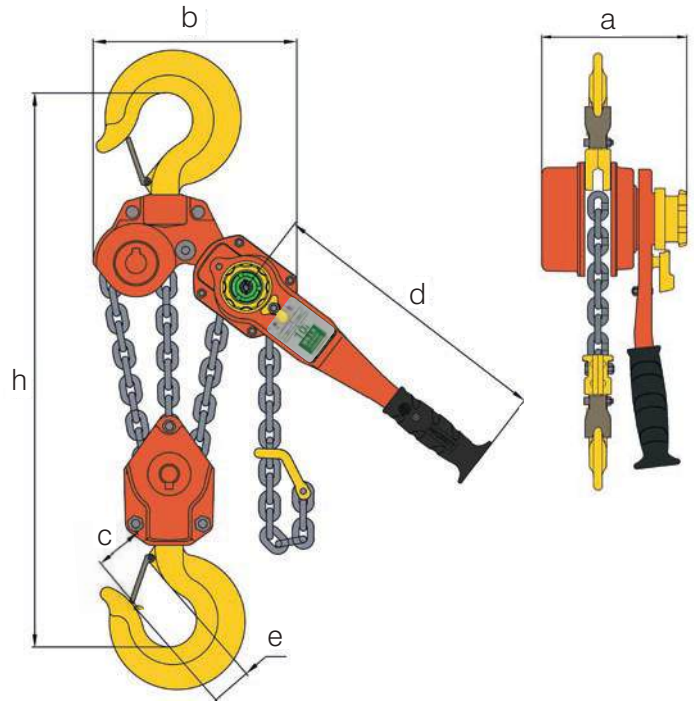

**Table 1: Product specification, dimensions and WLL for William Hackett SS-L5 QP lever hoists**

Part Code	WLL tonnes	No. of Falls	Load Chain mm	a mm	b mm	c mm	d mm	e mm	h min mm	Mass kg 1.5M HOL	Extra Weight per M kg
035.SS.080	0.8	1	5.6 x 17	146	119	41.5	245	27	280	5.9	0.70
035.SS.160	1.6	1	7.1 x 21	164	126	52.0	265	36	335	7.4	1.12
035.SS.320	3.2	1	10 x 30	196	159	61.9	415	42	395	13.7	2.23
035.SS.630	6.3	2	10 x 30	196	218	84.3	415	52.5	540	26.4	4.46
035.SS.1000	10.0	3	10 x 30	196	298	86.0	415	59	680	40.1	6.69
035.SS.1500	15.0	6	10 x 30	196	420	-	415	80	1000	94.4	13.38

## Hoist Selection

In accordance with statutory requirements (e.g. The Lifting Operations and Lifting Equipment Regulations 1998), all lifts using lever hoists should be planned by a competent person; require risk assessment and the production of a task method statement; and be subject to execution by suitably trained operatives under the supervision of a responsible person. The specification of the lever hoist required to achieve a safe lifting operation must be determined by a competent person.

It is not intended that the recommendations in this manual take precedence over existing plant safety rules and regulations or OSHA regulations. In the event that conflict exists between a rule set forth in this publication and a similar rule already set by an individual company, the more stringent of the two should take precedence.

Careful consideration should be given to the mass of the load being lifted and any dynamic factors that may be likely to affect the load on the hoist. Select the hoist capacity equal to or greater than the load. Ideally lever hoists should not be used to lift loads below 10% of their rated WLL limit.

William Hackett SS-L5 QP lever hoists are assembled, chained and tested in the UK to the height of lift specified by the end user. Careful consideration should be given to the headroom required to lift the load and the position of the operator before specifying the length of load chain and the hoist model.

The configuration of lever hoist assemblies are demonstrated on page 4, and are in accordance with the product specification, dimensions and working load limit (WLL) recorded in Table 1 (also on page 4).

William Hackett SS-L5 QP lever hoists are designed for the most demanding industrial applications in both indoor and outdoor, topside and subsea marine environments.

William Hackett SS-L5 QP lever hoists can be used within an operating temperature range of -40°C to +120°C.

William Hackett SS-L5 QP hoists are suitable for fleeting lifting. If multiple hoists are to be used in a fleeting operation, refer to document: "General Guidance for Fleeting Lifting".

A thorough study of the information in this manual should provide a better understanding of safe operating procedures and afford a greater margin of safety for people and equipment.

## Pre-use checks

Before the lever hoist is issued from the designated storage location a competent person must ensure that the appropriate certification is in place for the hoist.

Safe use instructions should be made available.

Possession of the relevant certification does not absolve the user from his responsibility to carry out pre-use inspections.

Conducting thorough and consistent checks on a lever hoist immediately prior to use will help identify problems due to accidental damage, internal corrosion, brake contamination or inappropriate storage.

Points to check before each period of use are:

- If necessary, the hoist should be cleaned before inspection.
- Name Plate – details clear and visible
- Hook latches in good working order
- Is the Load chain worn or damaged. In particular attention should be given to the wear which occurs on the bearing surfaces inside the links and to damage in the form of bent, notched, stretched, or excessively corroded links and the chain should move freely.
- Obvious signs of hooks opening out increase in throat opening or any other form of distortion in the hooks or suspension fittings.
- Top and bottom hooks free to rotate with no load applied.
- With no load applied turning the grip ring clockwise should produce a clear and positive clicking sound as the brake ratchet activates.
- On multiple fall hoists check that all chain sheaves are free to rotate whilst no load is applied.
- Check all fixings are in place and in good condition, split pins or nyloc nuts.
- Obvious signs of damage to the hoist slack end chain anchor.
- General damage to the hoist body, this can be an indicator of neglect throughout the hoist.
- The load chain wheel should be checked for damage or debris
- Chain guides and strippers should be free of debris and in good condition.

These checks should be performed with the hoist unloaded.

- Lifting function - select 'UP' and whilst pulling the load side of the chain, operate the lever handle clockwise, the ratchet brake mechanism shall engage operate smoothly without snagging.
- Lowering function - Select 'DN' and with a light pull of the load side chain, operate the lever counter clockwise, no clicking shall be audible and the chain should pay out smoothly.
- Neutral or free chaining - with the selector lever in the 'N' position. Pull the grip ring out. The chain shall then adjust freely via the grip ring or by pulling of the load chain.

**If any of these points are not satisfied the hoist MUST NOT be used.**



# Hoist Operation

## Load Chain Dual Anti-Lock Brake System (DABS) operation

The Hackett SS-L5 QP lever hoist may be used either in the vertical position as a hoist; or in an angled or horizontal position as a puller. Below is the general procedure for operating the hoist:



1. Locate the top hook securely.
2. To engage the chain adjustment mechanism position the selector lever in the neutral position  Neutral
3. Pull the grip ring out as shown in *figure 2*, the unloaded load chain can now be adjusted to the required position.
4. To re-engage hold the load chain to prevent chain travel and push the grip ring in with a clockwise motion as shown in *figure 3*.
5. To raise the load:  
Move the selector lever to the up position  Up and rotate the lever handle clockwise.
6. To lower the load:  
Move the selector lever to the down position  Down and rotate the lever handle counter clockwise.



Figure 2



Figure 3



Figure 4

## Adjustable Chain End Stop

IMCA guidance note D 028 June 2017 Rev. 2 "The Use of Chain Lever Hoists in the Offshore Environment" requires measures to avoid single point failures in static or multiple rigging points. The Hackett SS-L5 QP is fitted with a travelling chain end stop to specifically address the point in section 7.2 of the IMCA guidance notes. If the end stop is to be used, then it should be positioned as shown in *Figure 4* before the load is lowered. If a hoist has been left rigged under load for an extended period of time it is good practice to first lift the load slightly before lowering it.

Once the operation of lowering the load has started and the brake is fully holding the load, the travelling end stop can be returned to its normal position (*Figure 5*). It is important to move the end stop to its normal position after lowering has commenced otherwise the travelling chain end stop will come up against the body of the hoist.



Figure 5

## Safe Use information

Do not attempt lifting operations unless you understand the use of the equipment, the lifting and slinging procedures and you have been suitably trained.

William Hackett SS-L5 QP lever hoists are not designed for lifting people and should not be used for that purpose.

Use appropriate personal protective equipment (PPE).

Check the correct engagement of the top and bottom hooks. The hooks should be free to articulate within the load attachment points without overcrowding.

Do not use the handwheel whilst the hoist is loaded.

When the hoist is under load ensure that the selector lever is in the UP position.

Whilst loaded do not try to make chain adjustments by pulling the load chain.

Ensure that the work area is clear to avoid the slack end chain snagging in use.

Ensure that the suspension structure has sufficient load bearing strength and capacity to support the load.

Do not use the lever hoist as a chain sling; it is a lifting appliance and suitable lifting accessories should be incorporated into the lift plan to facilitate a safe lifting operation.

If more than one lever hoist is to be used, refer to document: "General Guidance for Fleeting Lifting".

Establish a clearly defined zone around the area of the lifting operation.

Always stand aside from the load when operating the hoist and ensure that no one enters the lift zone unintentionally during the lifting operation.

Ensure that the load chain is not twisted, particular care should be taken when using multi-fall hoists.

During the lift the load chain should be straight and should not contact any angles or edges.

Take the load steadily and avoid shock loads.

Do not expose SS-L5 QP lever hoist to chemicals or corrosive solutions (whether immersed in such solutions or used in atmospheres in which fumes are present), particularly acidic or strongly alkaline environments without consulting the supplier or manufacturer.

Do not leave suspended loads unattended. In an emergency cordon off the working area and establish safe exclusion zones.

Never return a damaged lever hoist to stores; it should be reported to a competent person.



## **Immersion Policy, Procedures and Storage Control**

The William Hackett SS-L5 QP can be deployed subsea in any single immersion for a period of up to 21 days and multi immersion for a period of 31 days. Please seek advice from William Hackett for periods of time beyond 21 days.

Check the SS-L5 QP lever hoist Service and Inspection Log for the number of exposures and the total duration the SS-L5 QP has been in use. The SS-L5 QP lever hoist can be used as many times as the project requires over 31 day multi immersion period however when the SS-L5 QP lever hoist is in between immersions the William Hackett Immersion Policy, Procedures and Storage Control must be adhered to. After the 21 day single immersion or 31 day multi immersion the SS-L5 QP lever hoist should be sent to an authorised William Hackett agent. The service should include a full strip down and inspection of internal components followed by a range of load tests carried out after re-assembly.

After each period of use subsea the hoist should be flushed with unpressurised fresh water, functionally checked and then stored in a dry storage area protected from the elements. Solvents or lubricants should not be used for cleaning the hoists.

Any defects should be reported to the responsible person and damaged hoists should be quarantined.

The load chain should be dried and wrapped around the hoist, not left on the floor.

During transport to the offshore worksite and whilst in store at the worksite, the equipment should be protected from exposure to any conditions which may affect its ability to operate safely. In particular, it should be protected from exposure to:

- water/sea water.
- temperatures higher than can be comfortably tolerated by the hand.
- temperatures below freezing point.
- solvents.
- corrosive chemicals or fumes.
- grit, sand and wind-blown dust.

Storage should be on suitable racks within a container in a manner that prevents accidental mechanical damage and where the load chains are clear from the ground.

The equipment should ideally be stored in purpose designed facility where it can be kept secure from unauthorised use. A responsible person should control the issue and receipt of all lifting appliances and accessories.

Duty holders and actual users of lifting equipment, including lever hoists and associated components can obtain more detailed information and guidance on safe use and compliance with statutory requirements from the following publications:

- DNV Salt Water Immersion Test Report No. A0359376.02, Rev. 1.
- HSE Publication L22 (2014) Safe Use of Work Equipment.
- HSE Publication L113 (2014) Safe Use of Lifting Equipment.
- HSE Publication INDG422 (2008) Thorough Examination of Lifting Equipment.
- HSE Publication L23 (2004) Manual Handling.
- HSE Publication L25 (2005) Personal Protective Equipment at Work.

## ***Practical Considerations in the Offshore Environment***

The use of lever hoists within static rigging with multiple components and directions of pull is common subsea and the William Hackett SS-L5 QP has a feature to mitigate the hazards associated with this. The Hackett SS-L5 QP is fitted with a moveable end stop, providing the full efficiency of the actual lever hoist, when fitted correctly after the lever hoist has been operated and the planned position of the load has been achieved. The end stop is moved as close as possible to the body of the lever hoist and even if the load comes off the lever hoist brake or the hoist moves by some external influence the hoist will remain connected in line and the load will remain supported. This removes the need for secondary or multiple rigging and overcomes any potential for single point failure, should the brake fail for any reason the load will only be able to move a matter of millimetres before the end stop comes into contact with the lever hoist body and held securely.

As with any item of lifting equipment, the lever hoist is given for a maximum working load limit. This should not be exceeded during any lifting operation. It is important, therefore, when planning an underwater lifting operation that the load to be lifted on the hoist is known or has been accurately estimated with an adequate allowance for safety. The possible effects of additional loading, such as friction, seabed suction and buoyancy, should be included when the lever hoist is being selected for the lift.

Please note the William Hackett SS-L5 QP lever hoist whilst in operation mode requires zero load to operate.

The design of chain lever hoists is such that a brake mechanism is used to suspend the load, but also requires a load to operate. This brake mechanism gives the lever hoist its versatility but also introduces limitations on its use. The brake relies on the load tension for its operation, so the hoist requires a weight or tension on the load chain before the brake mechanism will function and securely hold the load. Under very light load conditions, lever hoists have been known to pay out chain due to the lack of load on the brake. This has been a particular problem when, or immediately following, changing the hoisting direction from up to down or vice versa. When planning a lifting operation using a lever hoist or selecting a lever hoist for a lift, the light load limitation of the braking mechanism should be recognised and the hoist should not be used to lift a load that is less than 10% of the stated working load limit for that hoist.

The lever hoist is intended for straight line lifting. If used in a dynamic lifting arrangement, such as an adjustable leg in an overboarding rigging bridle, the changing loading may cause the hoist to fail or slip. As the load goes through the splash zone the weight could come off the brake mechanism and the chain could run out. The SS-L5 QP with the functionality of the travelling end stop, when positioned adjacent to the body of the lever hoist in the final rigged position before the lift commences, it would prevent any slippage in an overboard rigging application.

## ***Practical Considerations in the Offshore Environment***

The SS-L5 QP range of subsea lever hoists are suitable for use inverted and are approved for this mode of operation. The SS-L5 QP lever hoist is much more versatile than a chain block, as it can be used in any orientation due to specially designed chain guides. It is important, however, that the slack end chain is free to run smoothly through the block without 'hanging up'. When the lever hoist is used in an inverted orientation it is possible for the free end chain to bunch up, jam temporarily then release unexpectedly if not fed through cleanly.

# Spare Parts Inspection Category

Special Inspection			Standard Inspection		
Corrosion Protected / Stainless Steel Components (Do Not Shotblast)			Non-Corrosion Protected or Painted Components		
Part Code	Quantity	Description	Part Code	Quantity	Description
			SSL5.01	1	Gear Cover
			SSL5.02	2	Pinion Gear (pair)
SSL5.03	1	Pinion Shaft			
			SSL5.04	1	Load Gear
			SSL5.05	1	Gear Side Plate Assembly
			SSL5.06	1	Bearing
			SSL5.07	1	Load Sheave
			SSL5.08	2	Chain Guide
			SSL5.09	1	Chain Stripper
SSL5.QP.10	1	Lever Side Plate Assembly			
SSL5.QP.11	2	Stainless Steel Pawl Spring			
SSL5.QP.12A	1	Upper Pawl			
SSL5.QP.12B	1	Lower Pawl			
SSL5.13	2	Circlip			
SSL5.14	1	Disc Hub			
SSL5.QP.15	1	Ratchet Gear			
			SSL5.16	1	Brake Cover Assembly
			SSL5.17	2	Lever Side Plate Nyloc Nut (M6)
			SSL5.19	8	Lever Hoist Cover Nyloc Nut (M8)
SSL5.20	1	Change Gear			
SSL5.20L	1	Load Limiter			
			SSL5.21	1	Change Over Pawl
			SSL5.22	1	Change Over Stand
			SSL5.23	1	Change Over Spring
			SSL5.24	1	Handle Assembly
			SSL5.25	1	Screw
			SSL5.25A	1	Spring Washer
SSL5.26	1	Cam			
SSL5.27	1	Twisting Spring 1			
			SSL5.28	1	Grip Ring
SSL5.29	1	Twisting Spring 2			
			SSL5.QP.30	1	Spring Housing
			SSL5.31	1	Castle Nut
			SSL5.32	1	Split Pin
			SSL5.35	1	Chain End Fixing Pin Nyloc Nut
			SSL5.36	1	Bottom Hook Chain End Fixing Pin
			SSL5.37	2	Latch Kit
			SSL5.38	1	Bottom Hook Assembly
			SSL5.39	1	Top Hook Pin
			SSL5.40	1	Top Hook Assembly
			SSL5.42	1	Pinion Shaft Washer
			SSL5.47	1	Top Hook Chain Fixing Pin 6.3t and 10t
			SSL5.49	Per Metre	Calibrated Load Chain
			SSL5.50	1	Rubber Handle Nut
			SSL5.50A	1	Rubber Handle Bolt
			SSL5.60	2 Sets	Countersunk Screw and Nut
			SSL5.62	1	Rubber Handle with Enlarged Pommel
			8-064	1	Travelling End Stop
			SSL5.QP.63	1	Label
			SSL5.64	4	Label Rivets

# Parts List

Part Code	Part Name	Quantity	Finish	Included in Service Kit
SSL5.01	Gear Cover	1	Powder Coated	No
SSL5.02	Pinion Gear (pair)	2	Self Colour	No
SSL5.03	Pinion Shaft	1	Zinc Flake	Yes
SSL5.04	Load Gear	1	Self Colour	No
SSL5.05	Gear Side Plate Assembly	1	Powder Coated	No
SSL5.06	Bearing	2	Steel	Yes
SSL5.07	Load Sheave	1	Zinc Flake	No
SSL5.08	Chain Guide	2	Zinc Flake	No
SSL5.09	Chain Stripper	1	Zinc Flake	No
SSL5.QP10	Lever Side Plate Assembly	1	Powder Coated & Zinc Flake	Yes
SSL5.QP11	Stainless Steel Pawl Spring	2	Stainless Steel	Yes
SSL5.QP.12A	Upper Pawl	2	Zinc Flake	Yes
SSL5.QP.12B	Lower Pawl	2	Zinc Flake	Yes
SSL5.13	Circlip	2	Stainless Steel	Yes
SSL5.14	Disc Hub	1	Zinc Flake	Yes
SSL5.QP.15	Ratchet Gear c/w Friction Discs	1	Zinc Flake	Yes
SSL5.16	Brake Cover Assembly	1	Powder Coated	No
SSL5.17	Lever Side Plate Nyloc Nut (M6)	6	Stainless Steel	Yes
SSL5.19	Lever Hoist Cover Nyloc Nut (M8)	4	Stainless Steel	Yes
SSL5.20	Change Gear	1	Zinc Flake	Yes
SSL5.20L	Load Limiter	1	Zinc Flake / Mixed	No
SSL5.21	Change Over Pawl	1	Zinc Flake	No
SSL5.22	Change Over Stand	1	Zinc Flake	No
SSL5.23	Change Over Spring	1	Zinc Flake	No
SSL5.24	Handle Assembly	1	Powder Coated	No
SSL5.25	Screw	1	Stainless Steel	No
SSL5.25A	Spring Washer	1	Stainless Steel	No
SSL5.26	Cam	1	Zinc Flake	Yes
SSL5.27	Twisting Spring 1	1	Stainless Steel	Yes
SSL5.28	Grip Ring	1	Powder Coated	No
SSL5.29	Twisting Spring 2	1	Stainless Steel	Yes
SSL5.QP30	Spring Housing	1	Powder Coated	No
SSL5.31	Castle Nut	1	Stainless Steel	No
SSL5.32	Split Pin	1	Stainless Steel	No
SSL5.35	Chain Fixing Pin Nyloc Nut	1	Zinc Flake and Stainless Steel	No
SSL5.36	Bottom Hook Chain End Fixing Pin	1	Zinc Flake and Stainless Steel	No
SSL5.37	Latch Kit	2	Zinc Flake and Stainless Steel	No
SSL5.38	Bottom Hook Assembly	1	Powder Coated and Stainless Steel	No
SSL5.39	Top Hook Pin	1	Zinc Flake	No
SSL5.40	Top Hook Assembly	1	Powder Coated, Zinc and Stainless Steel	No
SSL5.42	Pinion Shaft Washer	1	Black	No
SSL5.47	Top Hook Chain Fixing Pin 6.3t and 10t	1	Zinc Flake	No
SSL5.49	Calibrated Load Chain	1	Zinc/Galvanised	No
SSL5.50	Rubber Handle Nut			No
SSL5.50A	Rubber Handle Bolt			No
SSL5.60	Countersunk Screw & Nut	2	Stainless Steel	Yes
SSL5.62	Rubber Handle with Enlarged Pommel	1	Rubber	No
8-064	Travelling End Stop	1	Powder Coated	No
SSL5.QP63	Label	1	Stainless Steel	No
SSL5.64	Label Rivets	4	Stainless Steel	No

# Parts Explosion

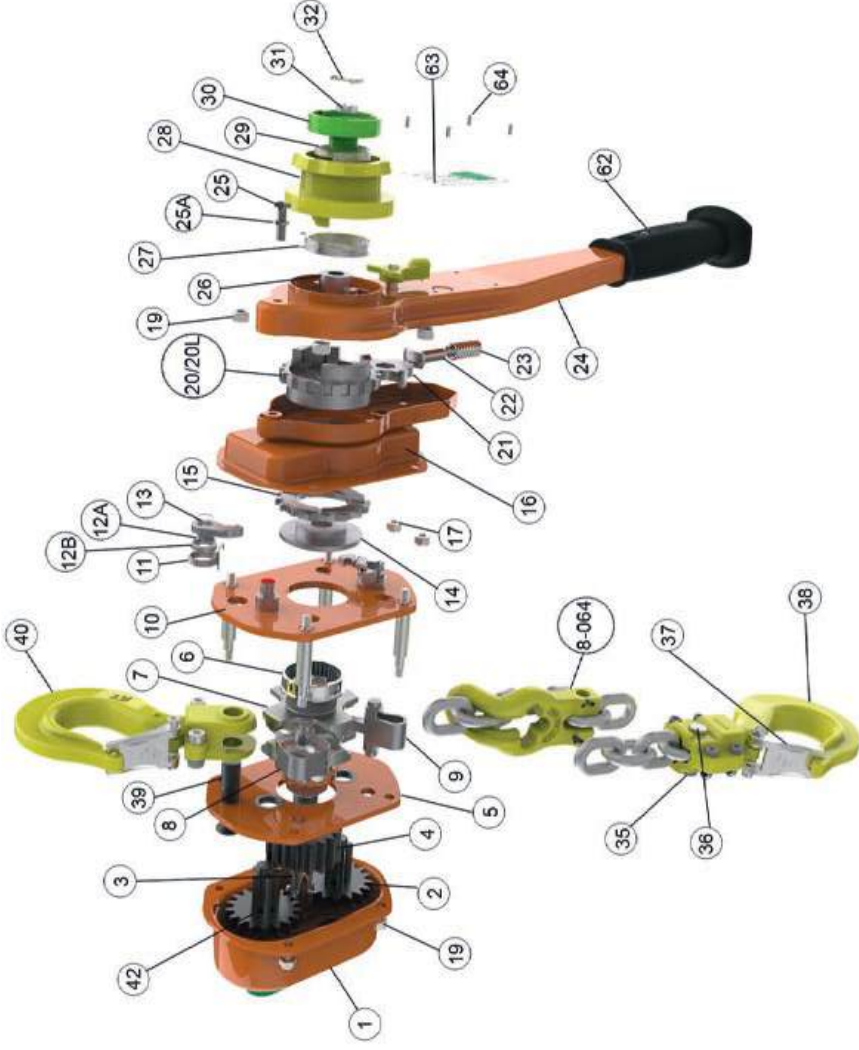

Part Code	Part Name
SSL5.29	Twisting Spring 2
SSL5.QP30	Spring Housing
SSL5.31	Castle Nut
SSL5.32	Split Pin
SSL5.35	Chain Fixing Pin Nyloc Nut
SSL5.36	Bottom Hook Chain End Fixing Pin
SSL5.37	Latch Kit
SSL5.38	Bottom Hook Assembly
SSL5.39	Top Hook Pin
SSL5.40	Top Hook Assembly
SSL5.42	Pinion Shaft Washer
SSL5.47	Top Hook Chain Fixing Pin 6.3t & 10t
SSL5.49	Calibrated Load Chain
SSL5.50	Rubber Handle Nut
SSL5.50A	Rubber Handle Bolt
SSL5.60	Countersunk Screw & Nut
SSL5.62	Rubber Handle with Enlarged Pommel
8-064	Travelling End Stop
SSL5.QP63	Label
SSL5.64	Label Rivets

Part Code	Part Name
SSL5.20L	Load Limiter
SSL5.21	Change Over Pawl
SSL5.22	Change Over Stand
SSL5.23	Change Over Spring
SSL5.24	Handle Assembly
SSL5.25	Screw
SSL5.25A	Spring Washer
SSL5.26	Cam
SSL5.27	Twisting Spring 1
SSL5.28	Grip Ring

Part Code	Part Name
SSL5.QP11	Stainless Steel Pawl Spring
SSL5.QP12A	Upper Pawl
SSL5.QP12B	Lower Pawl
SSL5.13	Circlip
SSL5.14	Disc Hub
SSL5.QP15	Ratchet Gear c/w Friction Discs
SSL5.16	Brake Cover Assembly
SSL5.17	Lever Side Plate Nyloc Nut (M6)
SSL5.19	Lever Hoist Cover Nyloc Nut (M8)
SSL5.20	Change Gear

Part Code	Part Name
SSL5.01	Gear Cover
SSL5.02	Pinion Gear (pair)
SSL5.03	Pinion Shaft
SSL5.04	Load Gear
SSL5.05	Gear Side Plate Assembly
SSL5.06	Bearing
SSL5.07	Load Sheave
SSL5.08	Chain Guide
SSL5.09	Chain Stripper
SSL5.QP10	Lever Side Plate Assembly

All Parts cross referenced with prefix (SSL5.) in Maintenance and Repair section

# Hoist Disassembly

## SS-L5 QP Servicing Tool Requirements (800kg - 10t)

Long nose pliers	Ball pein hammer
Circlip pliers	Sandpaper 120 - 240 grit
Phillips screw driver	Solvent free brake cleaner
Allen keys - 2.5mm, 3mm, 4mm, 5mm and 8mm	Corrosion block
Parallel/pin punches - 2.5mm, 3mm and 3.5mm	Vernier caliper
Nylon/dead blow hammer	Solvent free degreasing facility
Sockets or spanners sockets or spanners - 7mm, 8mm, 10mm, 12mm, 13mm, 14mm and 17mm	

The following procedures should only be performed by a competent person.

It is a responsibility of the owner/user to install, operate, inspect and maintain product in accordance with all applicable Standards and Regulations. If the product is installed as part of a lifting system, it is also the responsibility of the owner/user to comply with the applicable standards that address other types of equipment used.

NEVER perform maintenance whilst the hoist is under load. Always use OEM parts where replacement parts are necessary.

These instructions should be used alongside the illustrated parts list.

It is recommended to keep parts in order when disassembling to aid with assembly.

1. Remove and disassemble bottom hook 38, check all parts especially the load pin 36 for excessive wear.
  2. Remove and inspect travelling clutch using a parallel punch, it is recommended to use new roll pins when reinstalling.
  3. Remove load chain.
  4. Remove split pin 32 discard and replace.
  5. Remove parts 30 and 29, housing and spring.
  6. Lift the grip ring 28.
  7. Remove cam and twisting spring 26 and 27.
  8. Remove fixings 25 and 17.
  9. Lift the upper handle from its position 24 remove change over stand 22 and spring 23.
  10. The change gear 20 can now be removed by rotating anti-clockwise.
  11. Remove the 4 nyloc nuts from the brake housing and lift the brake cover assembly 16 from the body.
  12. Remove ratchet gear 15 and disc hub 14.
  13. Remove circlips 13 and pawls 12A and 12B.
  14. Remove the pawl spring 11.
  15. Turn the hoist over and remove the 4 nyloc nuts securing the gear cover 1.
  16. Remove the pinion gears 2 making a note of the alignment marks position 0.
  17. The pinion shaft 3 and pinion shaft washer 42 can now be removed from the gear side.
  18. Remove the top hook pin and top hook, remove hook housing nuts and bolts to inspect.
  19. Side plate 6 is now free to be removed giving access to all remaining parts.
- **Thoroughly clean all parts checking for damage excessive wear or foreign particles, if using a degreaser ensure all parts are dry and lubricated where necessary.**
  - **Please note split pins and nylon locking nuts should be replaced as they are single use only, it is also recommended to check the condition of circlip retainers and replace where necessary, all of which are stainless steel.**



# Maintenance and Repair

(Part codes are referenced in pages 15, 16 and depicted in the full parts explosion on page 17)

## SSL5.01 Gear Cover

Inspection Type: Visual  
Quantity: 1  
Finish: Powder Coated  
Included in Service Kit: No

Examine for cracks, distortion, damaged or broken parts, check gear bushings are secure and in good condition.

**Action: Shotblast and repaint or replace.**

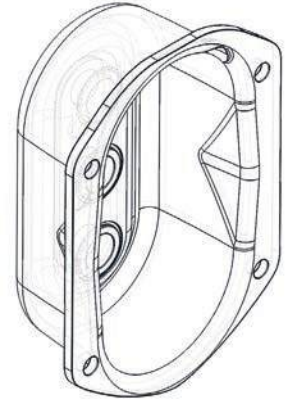

## SSL5.02 Pinion Gear

Inspection Type: Visual  
Quantity: 2  
Finish: Self Colour  
Included in Service Kit: No

Examine gears for wear, fractures, and alignment.

**Action: Clean, reapply grease or replace if necessary.**

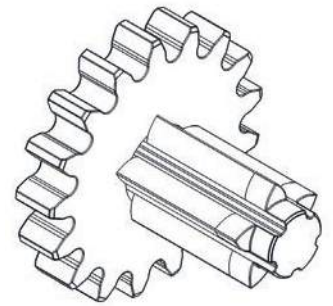

## SSL5.03 Pinion Shaft

Inspection Type: Visual  
Quantity: 1  
Finish: Zinc Flake  
Included in Service Kit: Yes

Examine pinion shaft for damage and distortion, check shaft for straightness, spline and thread condition.

**Action: Do not shotblast - replace.**



## SSL5.04 Load Gear

Inspection Type: Visual  
Quantity: 1  
Finish: Self Colour  
Included in Service Kit: no

Examine gear for wear, fractures, and alignment. Check condition of internal splines.

**Action: Clean, reapply grease or replace if necessary.**

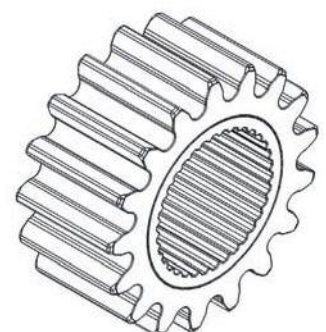

## Maintenance and Repair

### SSL5.05 Gear Side Plate Assembly

Inspection Type:	Visual
Quantity:	1
Finish:	Powder Coated
Included in Service Kit:	No

Examine gear side plates for alignment and ensure they are free from Damage and distortion, examine load pin, guide, stripper and stay bolt holes for signs of wear and stretch, check gear bushings are secure and in good condition.

**Action: Shotblast and repaint or replace.**

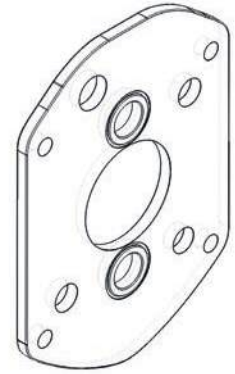

### SSL5.06 Bearing

Inspection Type:	Visual
Quantity:	2
Finish:	Steel
Included in Service Kit:	Yes

Examine bearings for excessive corrosion and wear. The bearings should be smooth and free to operate under slight pressure.

**Action: Clean, reapply grease or replace if necessary.**



### SSL5.07 Load Sheave

Inspection Type:	Visual
Quantity:	1
Finish:	Zinc Flake
Included in Service Kit:	No

Check load chain pockets for wear and damage, ensuring satisfactory seating of load chain in pockets. Check splines and internal bore for wear and damage.

**Action: Clean, reapply grease or replace if necessary.**

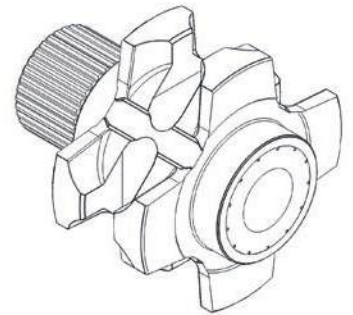

### SSL5.08 Chain Guide

Inspection Type:	Visual
Quantity:	2
Finish:	Zinc Flake
Included in Service Kit:	No

Examine chain guide for wear, fractures, and alignment.

**Action: Shotblast and repaint or replace.**

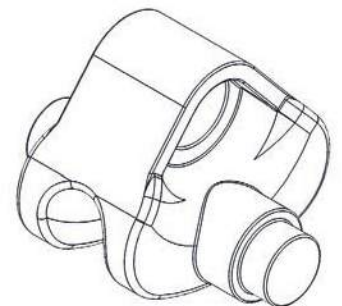

## Maintenance and Repair

### SSL5.09 Chain Stripper

Inspection Type:	Visual
Quantity:	1
Finish:	Zinc Flake
Included in Service Kit:	No

Examine chain stripper for wear or damage.

**Action: Shotblast and repaint or replace.**

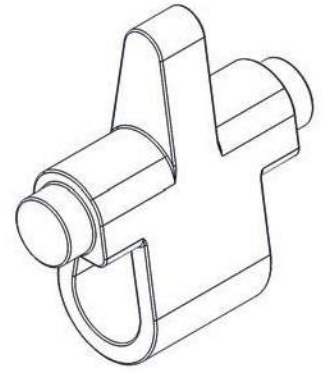

### SSL5.QP.10 Lever Side Plate Assembly

Inspection Type:	Visual
Quantity:	1
Finish:	Powder Coating and Zinc Flake
Included in Service Kit:	Yes

Examine body plates for alignment and ensure they are free from wear and distortion, examine load pin, guide and stripper holes for signs of wear and stretch, check stay bolts and pawl stands are secure and free from defects.

**Action: Do not shotblast - replace.**

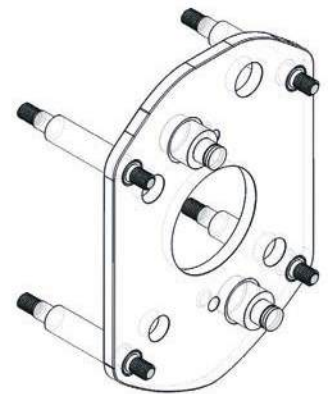

### SSL5.QP.11 Pawl Spring

Inspection Type:	Visual
Quantity:	2
Finish:	Stainless Steel
Included in Service Kit:	Yes

Examine pawl springs for corrosion and fractures, ensure the spring is in good working order and not deformed or stretched.

**Action: Do not shotblast - replace.**

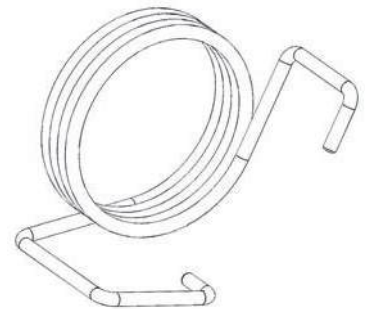

### SSL5.QP.12/12A Upper and Lower Pawl

Inspection Type:	Visual
Quantity:	2 x 12A, 2 x 12B
Finish:	Zinc Flake
Included in Service Kit:	Yes

Check pawl for wear and corrosion ensuring pawl is free to move on pawl shaft.

**Action: Do not shotblast - replace.**

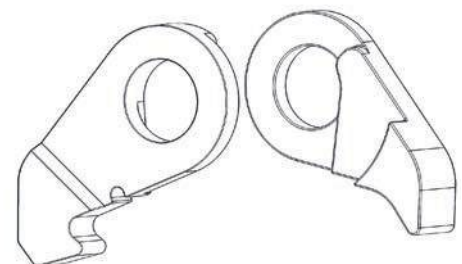

## Maintenance and Repair

### SSL5.13 Circlip

Inspection Type:	Not Applicable
Quantity:	2
Finish:	Stainless Steel
Included in Service Kit:	Yes

**Action: Do not shotblast - replace.**

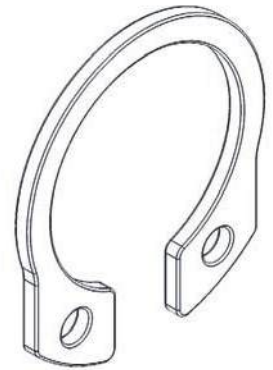

### SSL5.14 Disc Hub

Inspection Type:	Visual
Quantity:	1
Finish:	Zinc Flake
Included in Service Kit:	Yes

Check for damage and corrosion. Check splines and ensure the component mating surfaces are smooth and flat and without excessive corrosion.

**Action: Do not shotblast - replace.**

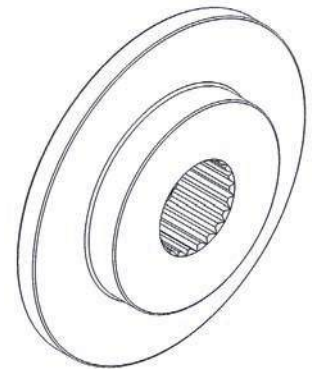

### SSL5.QP.15 Ratchet Gear

Inspection Type:	Dimensional
Quantity:	1
Finish:	Zinc Flake
Included in Service Kit:	Yes

Examine ratchet teeth and brake component surfaces ensuring they are smooth and flat. Check sintered disc against wear tolerances. Contact manufacturer.

**Action: Do not shotblast - replace.**

**\*See Page 36 for more information**

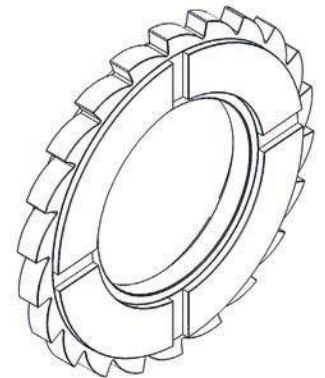

### SSL5.16 Brake Cover Assembly

Inspection Type:	Visual
Quantity:	1
Finish:	Powder Coating
Included in Service Kit:	No

Examine for damage and corrosion, check the selector lever bush is secure and in good condition, check the pressed assembly is secure, free to rotate and lubricated.

**Action: Shotblast and repaint or replace.**

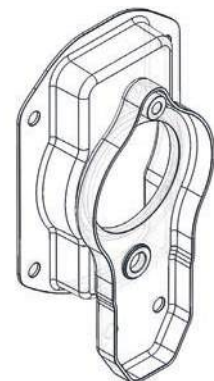

## Maintenance and Repair

### SSL5.17 Lever Side Plate Nyloc Nuts

Inspection Type:	Not Applicable
Quantity:	6
Finish:	Stainless Steel
Included in Service Kit:	Yes
Discard and replace.	

**Action: Replace.**

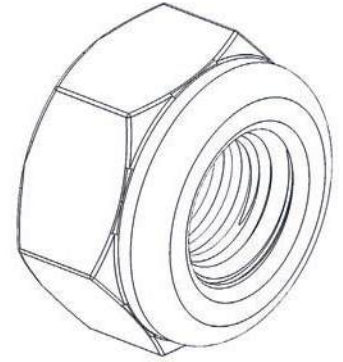

### SSL5.19 Lever Hoist Cover Nyloc Nuts

Inspection Type:	Not Applicable
Quantity:	4
Finish:	Stainless Steel
Included in Service Kit:	Yes
Discard and replace.	

**Action: Replace.**

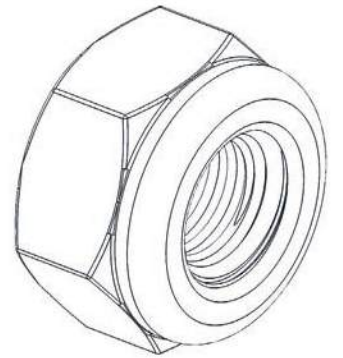

### SSL5.20 Change Gear

Inspection Type:	Visual
Quantity:	1
Finish:	Zinc Flake
Included in Service Kit:	Yes

Check mating surface is smooth and flat, check thread, lugs and pawl drive for damage, wear and corrosion.

**Action: Do not shotblast - replace.**

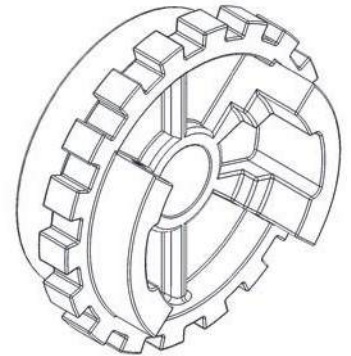

### SSL5.20L Load Limiter

Inspection Type:	Refer to load limiter manual
Quantity:	1
Finish:	Zinc Flake / mixed
Included in Service Kit:	No

**Action: Do not shotblast - replace.**

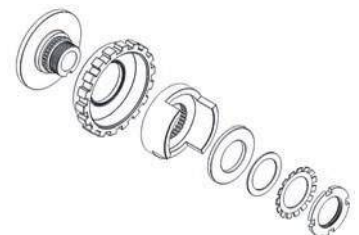



## Maintenance and Repair

### SSL5.21 Change Over Pawl

Inspection Type:	Visual
Quantity:	1
Finish:	Zinc Flake
Included in Service Kit:	No

Check pawl for wear, cracks, corrosion and damage, examine fit of pawl to selector lever shaft of handle. The pawl stand should not be bent or deformed, check spring dimensions as per diagram.

**Action: Clean, reapply grease or replace if necessary.**

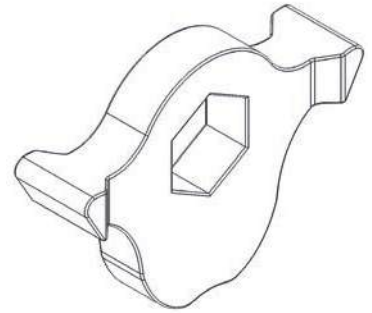

### SSL5.22 Change Over Stand

Inspection Type:	Visual
Quantity:	1
Finish:	Zinc Flake
Included in Service Kit:	No

Check stand for wear, cracks, corrosion and damage. The pawl stand should not be bent or deformed, check spring dimensions as per diagram.

**Action: Clean, reapply grease or replace if necessary.**

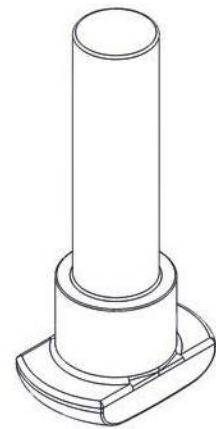

### SSL5.23 Change Over Spring

Inspection Type:	Visual
Quantity:	1
Finish:	Zinc Flake
Included in Service Kit:	No

Check spring for wear, cracks or damage.

**Action: Clean, reapply grease or replace if necessary.**

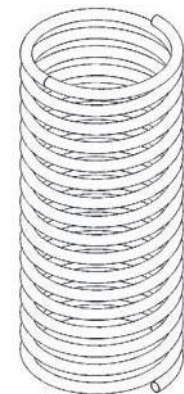

### SSL5.24 Handle Assembly

Inspection Type:	Visual
Quantity:	1
Finish:	Powder Coated
Included in Service Kit:	No

Examine lever for cracks, corrosion, distortion, damage and wear. Check selector lever function is smooth and secure. Check grip/handle is of good condition and secure. Check handle assembly fixings are of good condition. **Action: Shotblast and repaint or replace.**



## Maintenance and Repair

### SSL5.25/25A Screw and Spring Washer

Inspection Type:	Visual
Quantity:	1
Finish:	Stainless Steel
Included in Service Kit:	No

Check threads and washer condition.

**Action: Replace if necessary.**

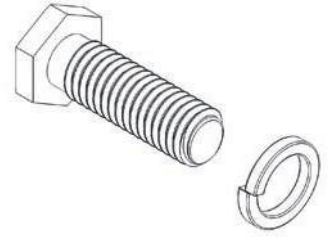

### SSL5.26 Cam

Inspection Type:	Visual
Quantity:	1
Finish:	Zinc Flake
Included in Service Kit:	Yes

Check splines and ensure the component mating surfaces are smooth, flat and without corrosion or wear.

**Action: Do not shotblast - replace.**

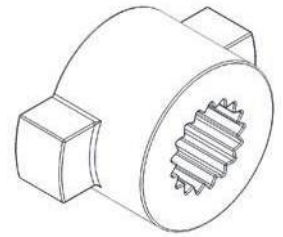

### SSL5.27 Twisting Spring 1

Inspection Type:	Visual
Quantity:	1
Finish:	Stainless Steel
Included in Service Kit:	Yes

Check twisting spring for damage, fractures and over extension.

**Action: Do not shotblast - replace.**

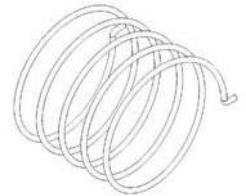

### SSL5.28 Grip Ring

Inspection Type:	Visual
Quantity:	1
Finish:	Powder Coated
Included in Service Kit:	No

Check grip ring for wear and damage, pay attention to cam and spring contact points.

**Action: Shotblast and repaint or replace.**

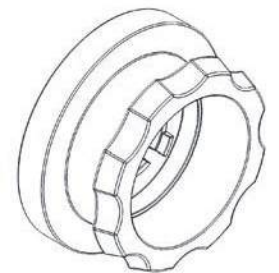



## Maintenance and Repair

### SSL5.29 Twisting Spring 2

Inspection Type:	Visual
Quantity:	1
Finish:	Stainless Steel
Included in Service Kit:	Yes

Check twisting spring for damage, fractures and over extension.

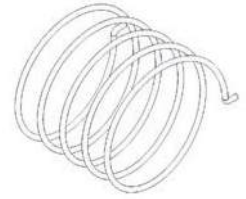

**Action: Do not shotblast - replace.**

### SSL5.QP.30 Spring Housing

Inspection Type:	Visual
Quantity:	1
Finish:	Powder Coated
Included in Service Kit:	No

Check for damage and wear, pay attention to outer diameter and locating splines.

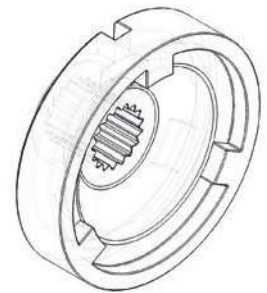

**Action: Shotblast and repaint or replace.**

### SSL5.31 Castle Nut

Inspection Type:	Visual
Quantity:	1
Finish:	Stainless Steel
Included in Service Kit:	No

Check thread condition, check for wear and fractures.

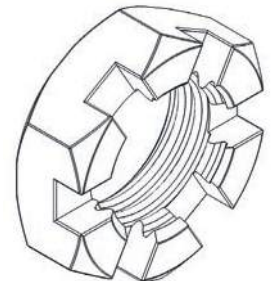

**Action: Replace if necessary.**

### SSL5.32 Split Pin

Inspection Type:	Not Applicable
Quantity:	1
Finish:	Stainless Steel
Included in Service Kit:	No

Discard and replace.

**Action: Replace.**



## Maintenance and Repair

### SSL5.35/36 Bottom Hook Bolt and Nut

Inspection Type:	Visual
Quantity:	1
Finish:	Zinc Flake and Stainless Steel
Included in Service Kit:	No

Check for wear and damage.

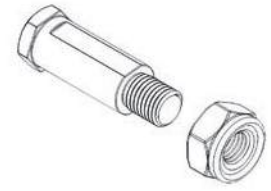

**Action: Check and replace if necessary.**

### SSL5.37 Latch Assemblies

Inspection Type:	Visual
Quantity:	2
Finish:	Zinc/Stainless Steel
Included in Service Kit:	No

Latch assemblies should be secure and free/smooth to open and close.  
Springs and bolts should be free from cracks and damage.



**Action: Shotblast and repaint or replace.**

### SSL5.38 Bottom Hook Assembly

Inspection Type:	Dimensional and Visual - contact manufacturer
Quantity:	1
Finish:	Powder Coated and Stainless Steel
Included in Service Kit:	No

Check for distortion, damage, corrosion fractures and stretching. The hook should be free and smooth to rotate, the hook to housing contact points should have even wear.

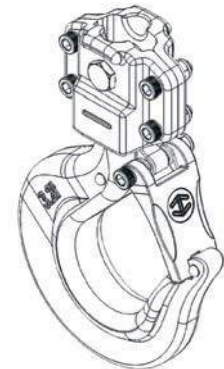

**Action: Shotblast and repaint or replace.**

### SSL5.39 Top Hook Pin

Inspection Type:	Visual
Quantity:	1
Finish:	Zinc Flake
Included in Service Kit:	No

Check for damage, wear and corrosion.

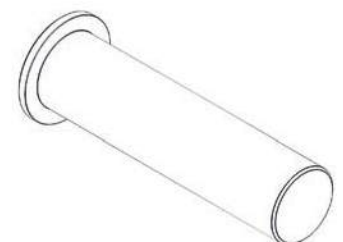

**Action: Check and replace if necessary.**

## Maintenance and Repair

### SSL5.40 Top Hook Assembly

Inspection Type: Dimensional and Visual - contact manufacturer

Quantity: 1

Finish: Powder Coated, Zinc Flake and Stainless Steel

Included in Service Kit: No

Check for distortion, damage, corrosion, fractures and stretching. The hook should be free and smooth to rotate, the hook to housing contact points should have even wear.

**Action: Shotblast and repaint or replace.**

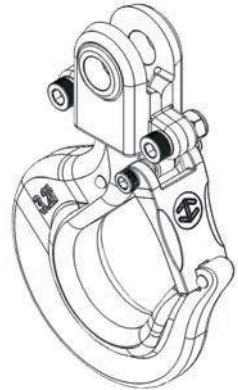

### SSL5.42 Pinion Shaft Washer

Inspection Type: Visual

Quantity: 1

Finish: Black

Included in Service Kit: No

Washer should be smooth, without damage and of good condition.

**Action: Clean, reapply grease or replace if necessary.**

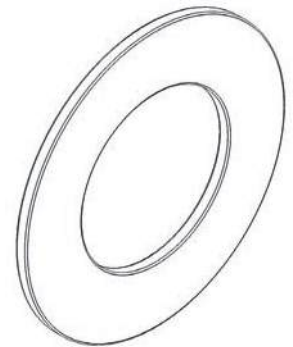

### SSL5.47 Top Hook Chain Fixing Pin 6.3t & 10t

Inspection Type: Visual

Quantity: 1

Finish: Zinc Flake

Included in Service Kit: No

Check for damage and wear.

**Action: Check and replace if necessary.**

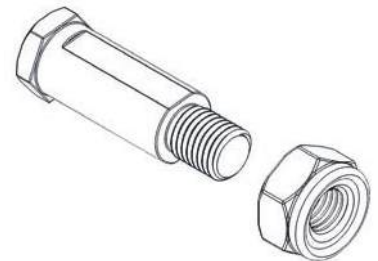

### SSL5.62 Handle Assembly

Inspection Type: Visual

Quantity: 1

Finish: Rubber

Included in Service Kit: No

Ensure the rubber grip is free from damage and secure.

**Action: Check and replace if necessary.**



## Maintenance and Repair

### 8-064 Travelling End Stop

Inspection Type:	Visual
Quantity:	1
Finish:	Powder Coated.
Included in Service Kit:	No

Check for damage and wear on all components of the stop, pay attention to chain contact points including load pin. Load pin retainers shall be secure on reassembly.

**Action: Shotblast and repaint or replace.**

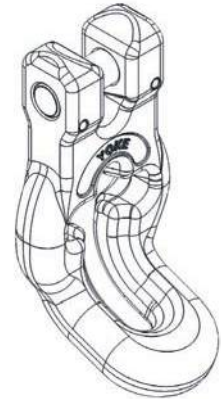

### SSL5.63 Label and Rivets

Inspection Type:	Visual
Quantity:	1 + 4 Rivets
Finish:	Stainless Steel
Included in Service Kit:	No

Check nameplate is secure and in good condition, the unique hoist serial number, WLL, HOL, chain grade and dimension should all be legible.

**Action: Check and replace if necessary.**

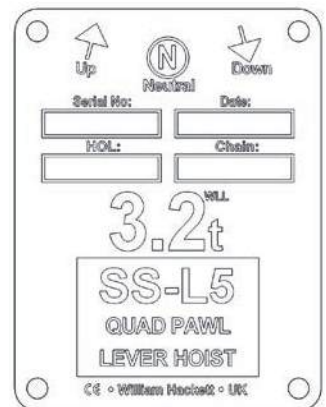

### Load Chain

Inspection Type:	Dimensional and Visual - see miscellaneous
Quantity:	1
Finish:	Zinc/Galvanised
Included in Service Kit:	No

Chain should be removed from hoist and laid flat on a clean work surface so all four sides can be inspected, all links must be inspected, checks shall include pitch, diameter, interlink wear, cuts, nicks, gouges, excessive corrosion in the form of pitting, bent or stretched links, batch, grade, length (is it correct to nameplate?). The chains should articulate freely.

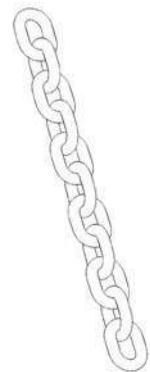

## Assembly Instructions

1. Lubricate the caged roller bearings using manufacturer specified marine grease, insert into the side plates 5 and 10 ensuring the bearing retaining clip is secured against the inner section of the side plates.
2. Insert load sheave with the splined section away from the wheel side plate.
3. Insert chain stripper, chain guides 7, 8 and 9 to the lever side plate assembly 10, ensure the chain stripper is located correctly so that when the hoist is hung vertically the stripper is directly below the top hook.
4. Position gear side plate 5 over all the assembled parts.
5. Turn the hoist so that the gear side plate faces up then attach load gear 4 over the splined load sheave section.
6. Lightly grease the pinion shaft complete with washer 3 and 42 then insert into the load sheave.
7. Apply a substantial coating of grease to the pinion gears then align timing marks according to diagram (Fig. a) below.
8. Fit gear cover 1 and install and tighten stainless steel nyloc nuts to secure.
9. Turn the hoist so that the brake side faces up, install pawl spring assembly 11, pawls 12A and 12B and circlips 13.
10. Fit the disc hub 14, ratchet gear 15 ensuring the ratchet engages the pawls correctly.
11. Install brake cover assembly securing with stainless steel nylocs 16 and 19.
12. Install change gear 20 by turning clockwise until full mated to the ratchet disc, this can be indicated by the pawl mechanism clicking.
13. Install change over pawl, stand and spring 21, 22 and 23 into the handle assembly 24 then fit to the brake cover assembly, secure with fixings 17, 25 + 25A.

You are now ready for the dual brake installation, refer to separate instructions on the following pages.

## Brake set-up

1. Turn the change-over gear #20 clockwise until the brake ratchet can be heard. Make sure the change-over gear is fully seated on the ratchet gear (Fig. 1).

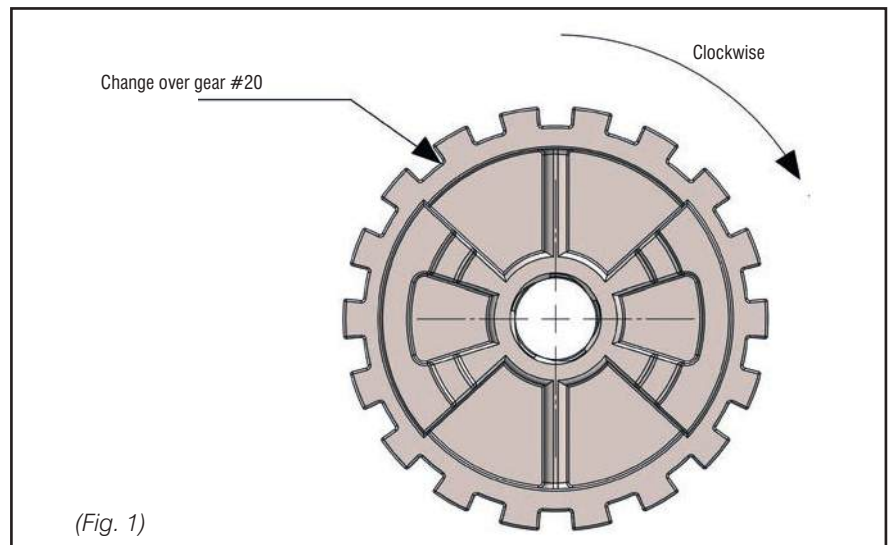

2. Put Cam #26 onto the pinion shaft #3. The bottom of the cam should be towards the change over gear #20. The cam should be positioned between  $0^{\circ}$  -  $11.5^{\circ}$  (Fig.2).

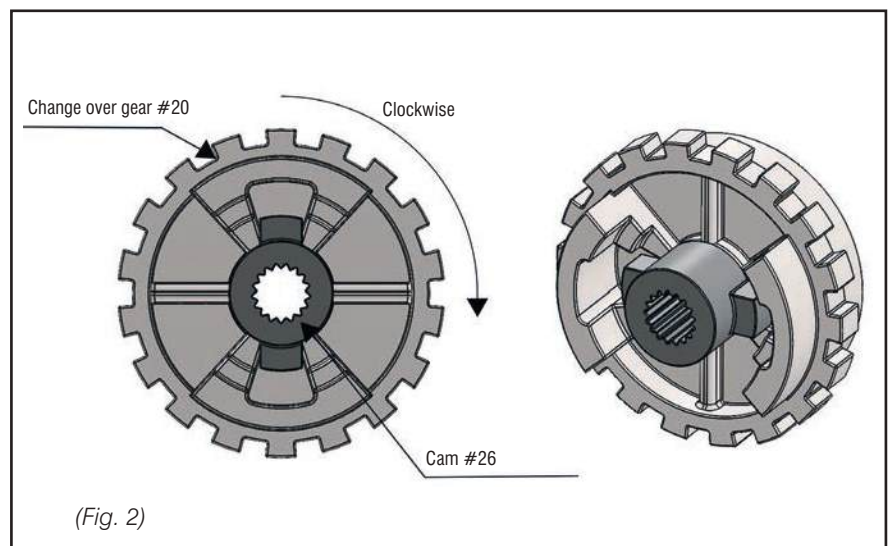

3. Fit twisting spring 1 #27 into the grip ring #28. The protruding part of the twisting spring should be fitted against the protruding part of the grip ring (Fig. 3).

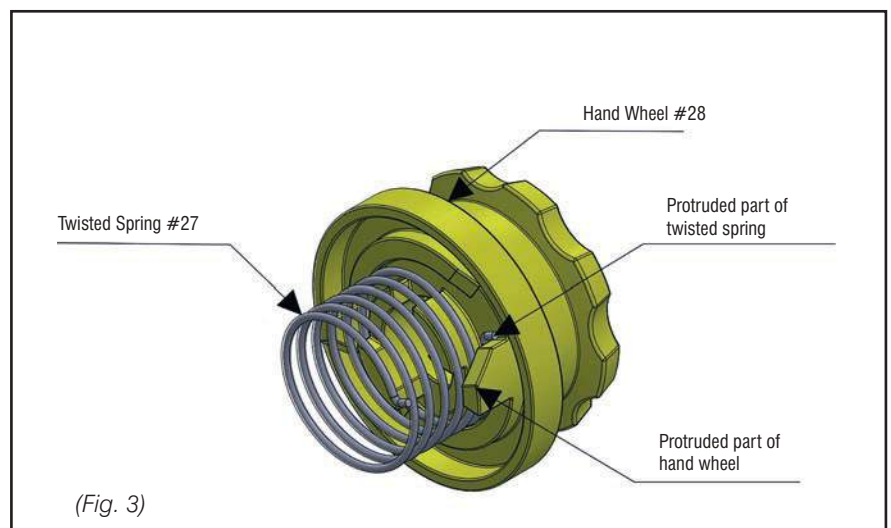



## Brake set-up

4. Fit the grip ring #28 with twisting spring 1 #27 into the change-over gear #20. The protruding twisting spring should be on the left hand side of the protruding part of the change-over gear #20 (Fig. 4).

Tension the spring clockwise by turning the grip ring 120° with a downwards motion until the grip is level with cam #26 (Fig. 5).

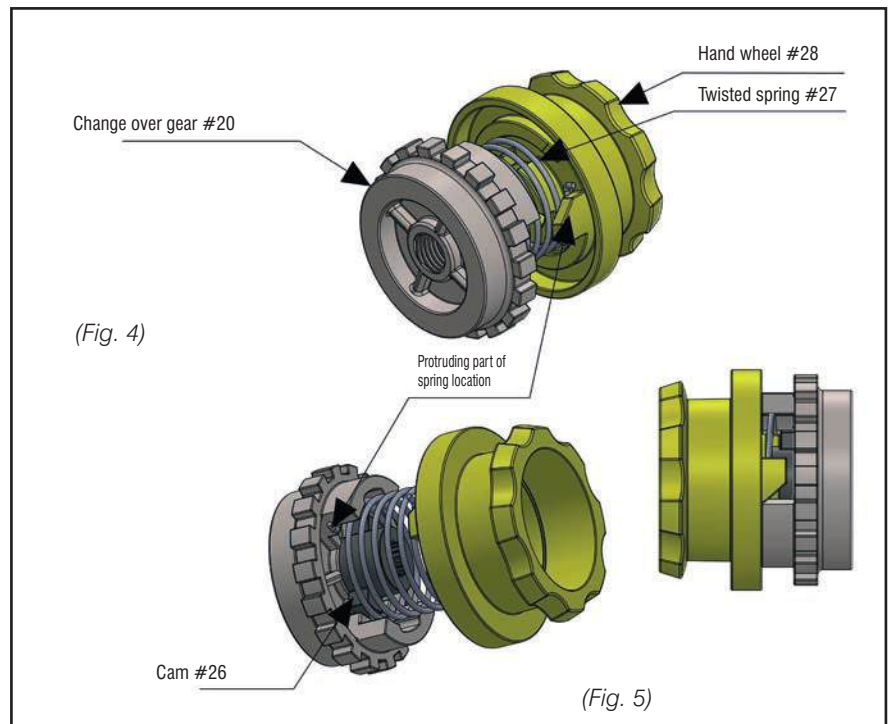

5. The selector lever can now be put into the up or down position to aid assembly (Fig. 6).

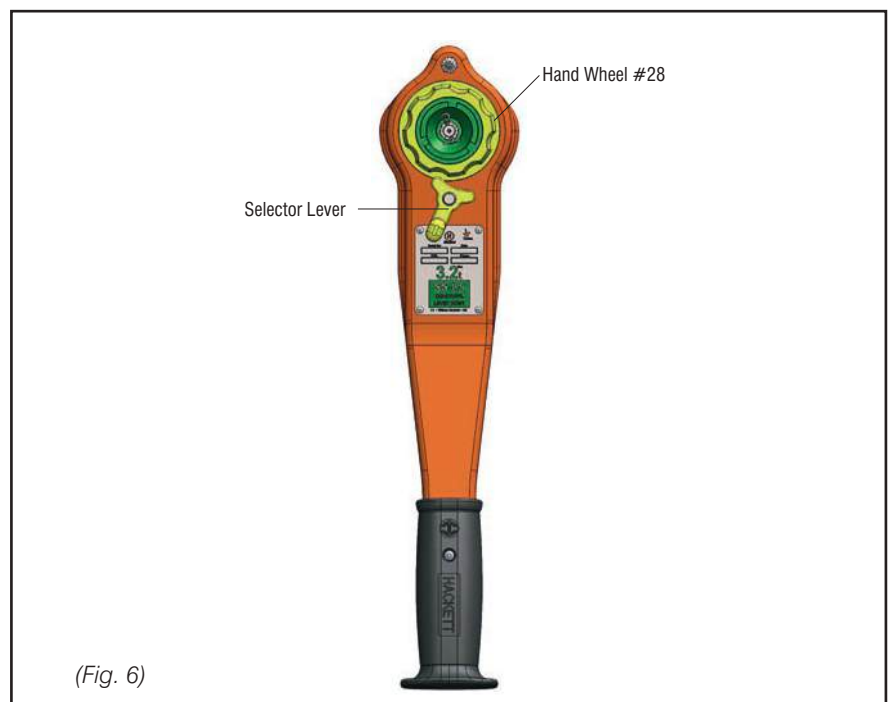



## Brake set-up

6. Fit twisting spring 2 #29 into locating hole in the edge of the twisting spring housing #30 (Fig.7).

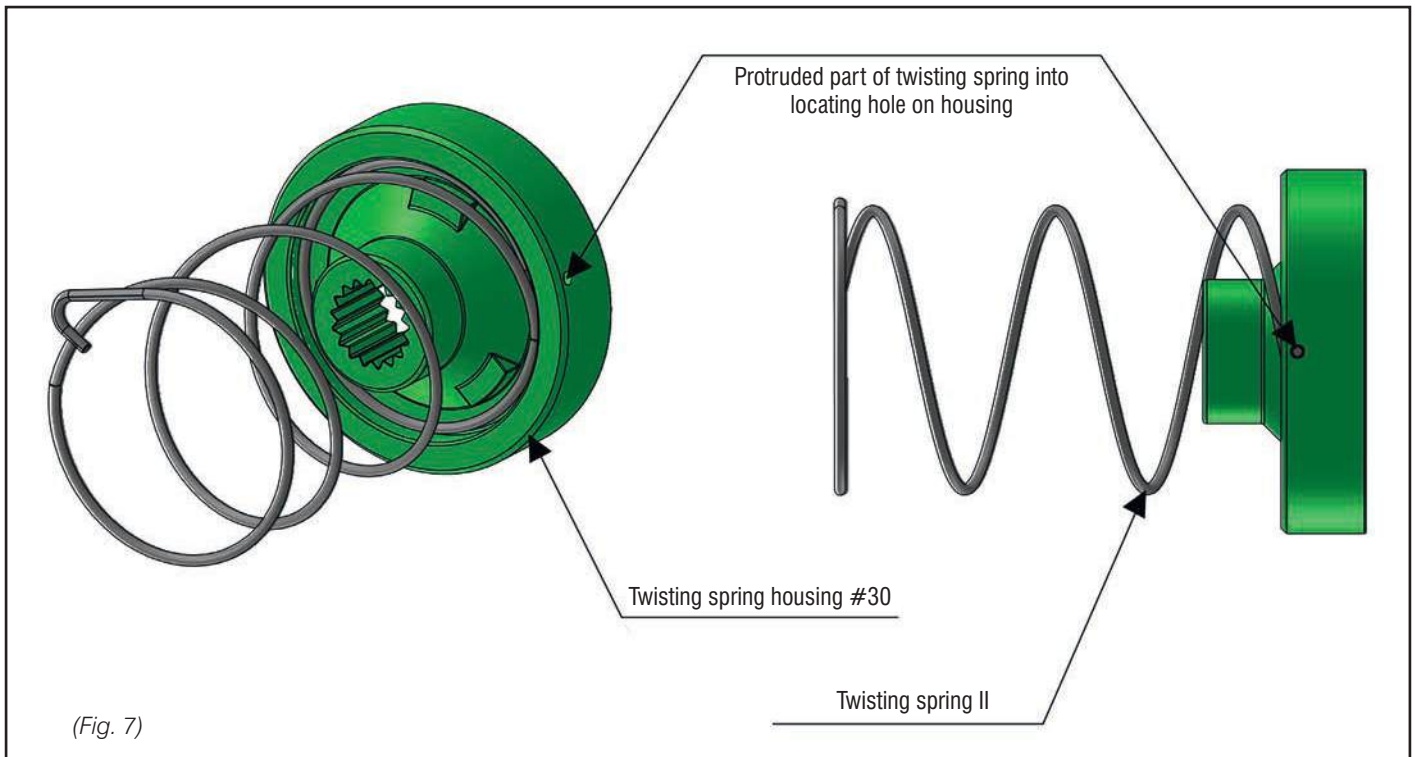

7. Fit the twisting spring housing #30 complete with twisting spring 2 #29 into the grip ring #28. (Fig. 8).

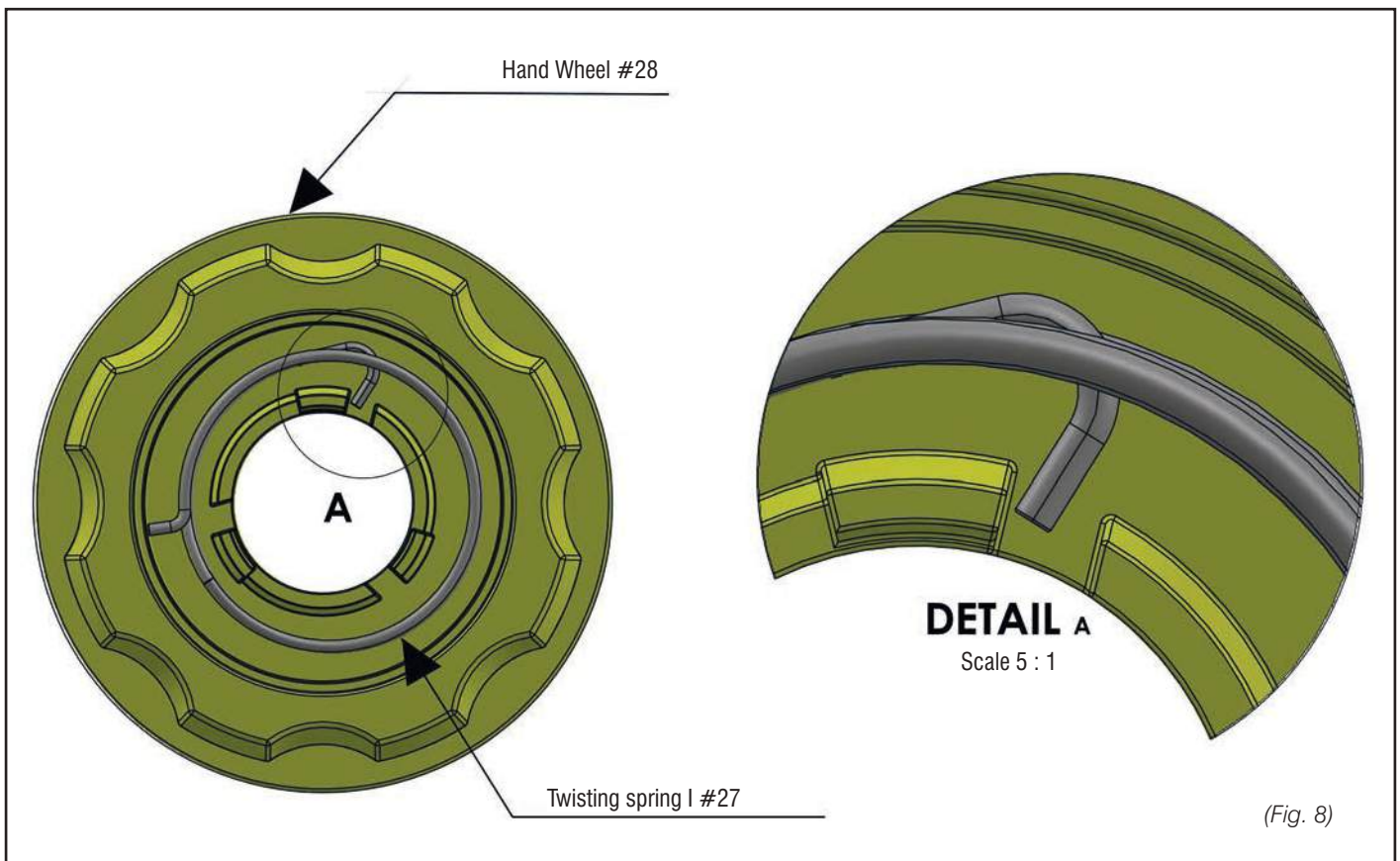

## Brake set-up

8. The protruding part of the twisting spring is to be fitted against the right hand side of the raised section of the handwheel #28. (Fig. 8)

To tension the twisting spring turn the housing #30 120° anti-clockwise then fit the housing onto the splined section of the pinion shaft #3.

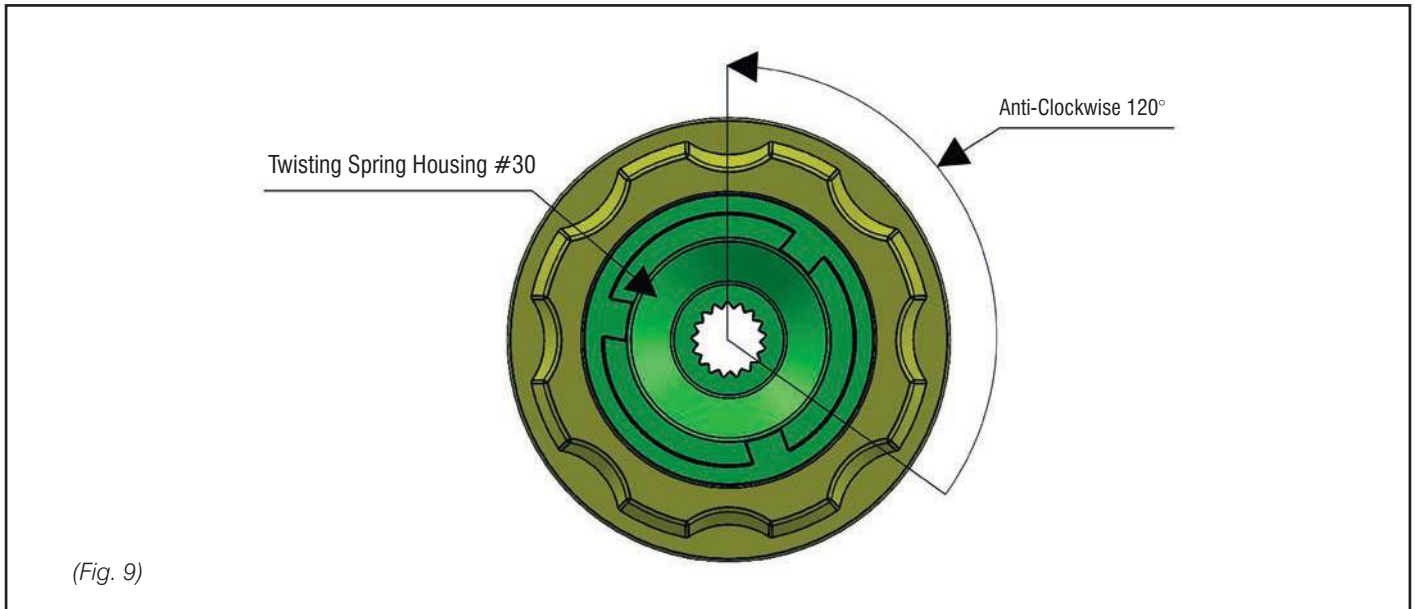

9. While holding the twisting spring housing down, fit the castle nut #31 finger tight against the housing then insert split pin and bend split pin ends over to secure (Fig. 10).

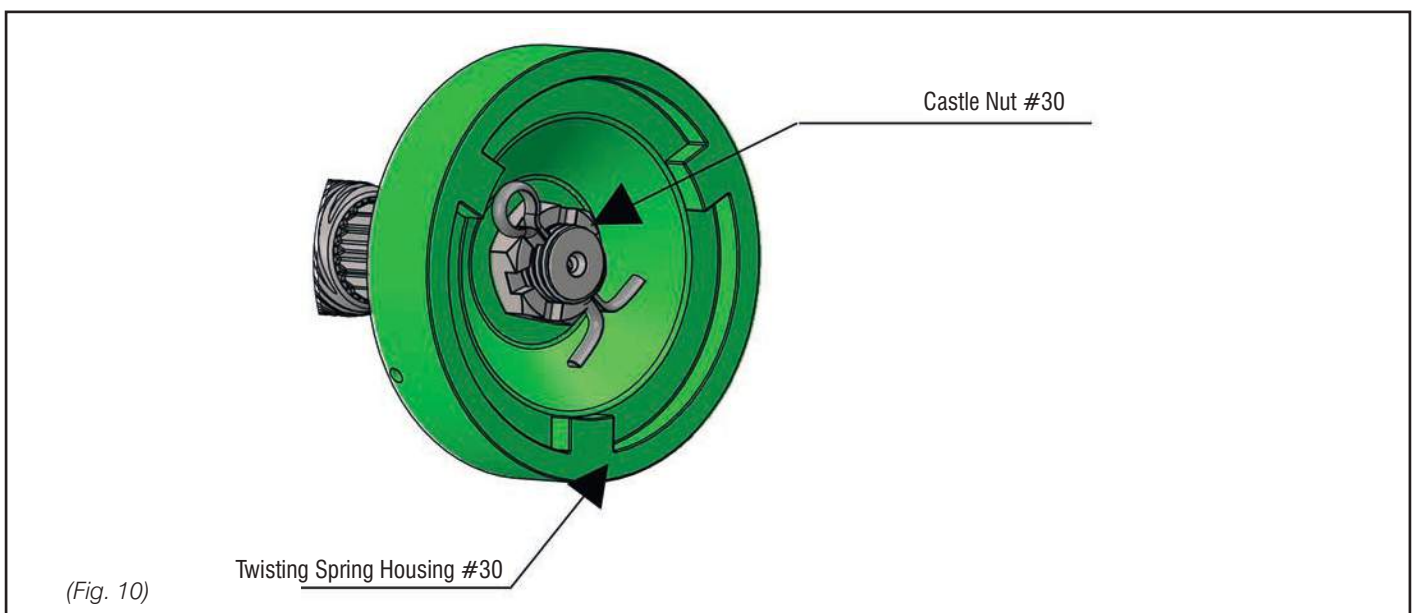

## Brake set-up



### Inspection

1. Move the selector lever to neutral and make sure the hoist is in operation mode.
  - a) When the grip ring is turned clockwise it should be free and rotate smoothly.
  - b) In operation mode the hand wheel shall not rotate anti clockwise
2. When the grip ring is pulled slightly it should return to its original position.
3. When the grip ring is pulled firmly the hoist should now be in rigging/free chain mode, the grip ring should turn freely in clockwise and anti clockwise motions, the load chain shall also be free to adjust/rig the hoist.
4. To re-engage operation mode it is a simple matter of restricting the upwards motion of the load chain, one of the following methods can be applied:
  - a) Holding the load side of the chain whilst turning the grip ring clockwise with a slight inwards pressure.
  - b) As above but this time gripping the load side and slack side chain
  - c) Holding the spring housing whilst turning the grip ring clockwise again with a slight inwards pressure.
5. The hoist should now pass a light load test of 2% in free wheel mode.

# Miscellaneous

## RATCHET WHEEL WITH BRAKE LININGS

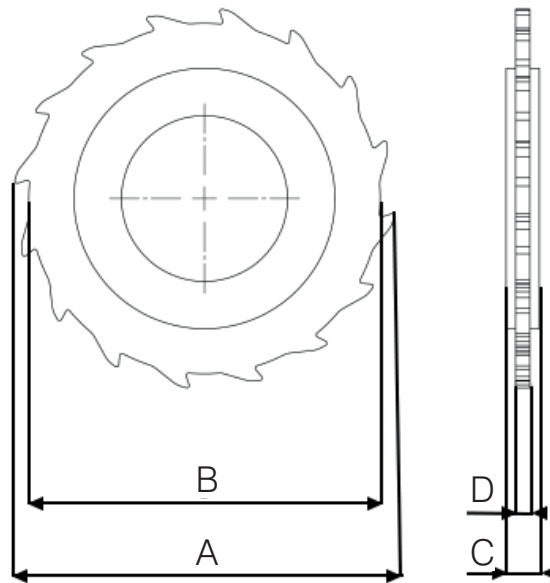

WLL t	A mm	B min mm	C mm	D min mm
0.8	64	61	8	6
1.6	64	61	8	6
3.2	74	71	8	6
6.3	74	71	8	6
10.0	74	71	8	6
15.0	74	71	8	6

## QUAD PAWL DIMENSIONS

### Pawl A

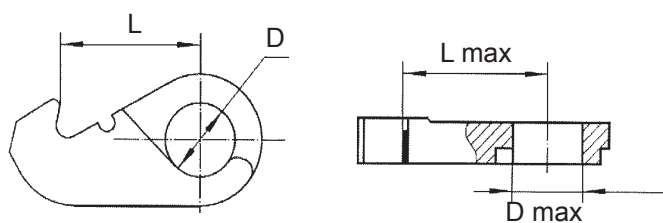

Capacity t	L mm	L max mm	D mm	D max mm
0.8 to 1.6	18.1	19.0	9	9.5
3.2 to 15.0	22.1	23.2	11	11.5

### Pawl B

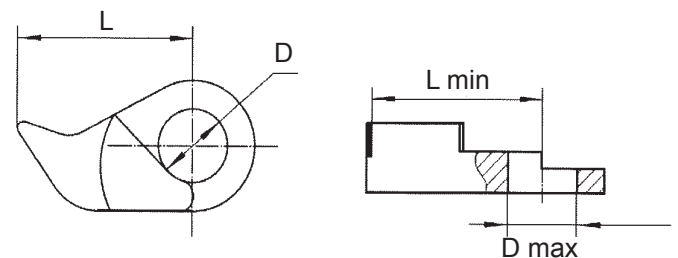

Capacity t	L mm	L max mm	D mm	D max mm
0.8 to 1.6	22.7	21.5	9	9.5
3.2 to 15.0	26.9	25.5	11	11.5

## Miscellaneous

### TORQUE VALUE TABLE

Bolt/nut size	Min Nm	Max Nm
M5	5	6
M6	6	8
M8	20	22
M10	22	24
M12	25	27

### LUBRICATION

#### SS-L5 QP Chain Hoist

Recommended lubricant type: Lear Chem Corrosion Block Grease

#### SS-L5 QP Chain Hoist Load Chain

Recommended Lubricant: Lear Chem ACF-50 fluid or Lear Chem Corrosion Block Fluid

### GEAR ALIGNMENT

#### 800kg - 15 tonnes

Note the 0 mark on the gears. These two marks must be on the horizontal centre line, the left hand gear with the 0 mark facing towards the centre and the 0 mark facing away from the centre as shown in Figure a.

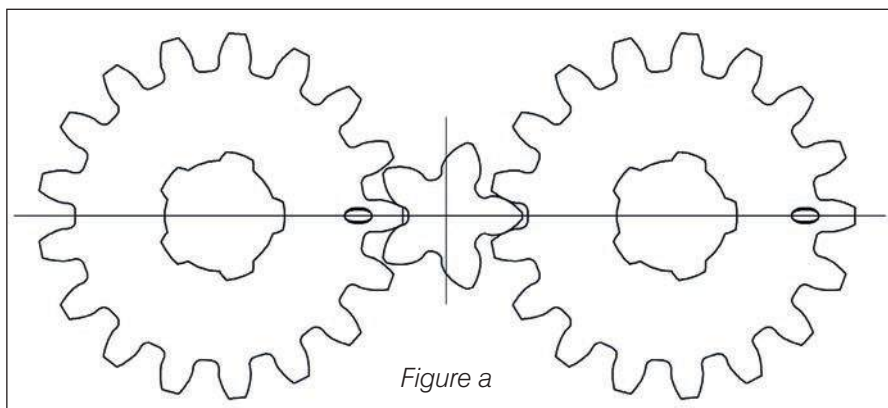

Alignment lettering may vary from batch to batch

# Miscellaneous

## LOAD AND WEAR LIMITS

### Alloy Steel Chain

Carefully inspect entire load chain. Measure five consecutive links with calipers to measure the length. Check every metre and especially where excessive wear is indicated. Any load chain that shows noticeable deformation or heat influence especially must be replaced with a new one. Never extend load chain by welding a second piece to the original.

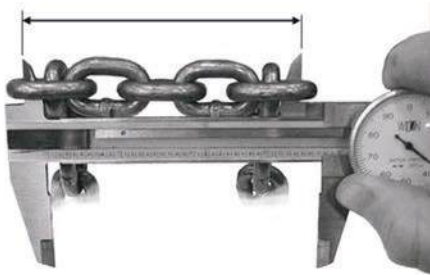
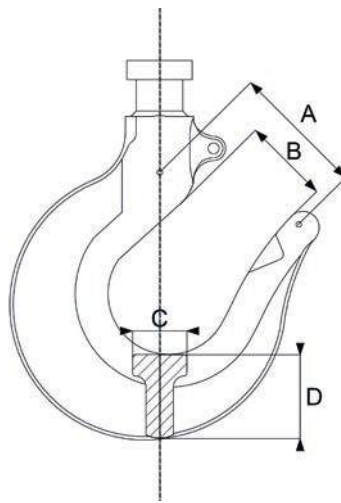

Figure 2

Capacity t	5 Links Normal mm	5 Links Limit Replace if more than:
0.8	85	87.5
1.6	105	108.1
3.2 - 15.0	150	154.3

## SS-L5 QP DIMENSIONS AND DISCARD CRITERIA



Capacity t	A (mm)		B (mm)		C (mm)		D (mm)	
	Nominal	Discard	Nominal	Discard	Nominal	Discard	Nominal	Discard
0.8	42.5	46.8	26.5	29.2	14.2	12.8	20.0	18.0
1.6	51.5	56.7	34.5	38.0	19.0	17.1	26.5	23.9
3.2	61.0	67.1	42.5	46.8	24.4	22.0	31.2	28.1
6.3	85.0	93.5	52.6	57.9	34.0	30.6	45.4	40.9
9.0	89.0	97.9	63.5	69.9	40.0	36.0	60.4	54.4
10.0	89.0	97.9	63.5	69.9	40.0	36.0	60.4	54.4
15.0	-	-	83.0	91.3	56.0	50.4	84.8	76.3

# Warranty

When supplied new the SS-L5 QP lever hoist will be supplied with a Declaration of Conformity which sanctions the use of the product for a maximum period of 12 months before re-certification is required by a competent person.







Providing that the use, storage, routine maintenance and servicing instructions contained in this document are followed the SS-L5 QP lever hoist can be used for multi immersions

The SS-L5 QP lever hoist is a lifting appliance and should be thoroughly examined by a competent person at least every 12 months, or following each period of deployment.

Only original William Hackett spare parts should be used.

William Hackett guarantee the performance of the SS-L5 QP lever hoist for a period of 12 months from the date of sale subject to the purchaser and users complying with the safe use, storage, routine maintenance and servicing instructions, and there being no excessive wear and tear or misuse of the product.

These points do not affect the purchasers statutory rights.

				   				<b>DUAL PURPOSE DOCUMENT</b>	
				<b>EC DECLARATION OF CONFORMITY DECLARATION</b>				<b>A</b>	
				I DECLARE THAT THE ITEMS DESCRIBED ON THIS DOCUMENT COMPLY WITH THE REQUIREMENTS OF THE MACHINERY DIRECTIVE 2006/42/EC					
<b>Delivery Address</b> ABC DISTRIBUTORS ALPHABET DRIVE ALPHABETTUS YOURCOUNTY YO13 ABC				<b>Supplied To:</b> ABC001 <b>Certificate Number:</b> L000000 <b>Customer Order No:</b> 1234 <b>Date Received:</b> 07/02/2020				<b>B</b>	
				<b>MANUFACTURER'S CERTIFICATE</b> CERTIFIED ON BEHALF OF THE COMPANY  T.J. BURGESS 07/02/2020					
PRODUCTS REQUIRING A DECLARATION OF CONFORMITY ARE INDICATED BY (A) THOSE REQUIRING JUST A MANUFACTURER'S CERTIFICATE BY (B)									
<b>Authorised person for the configuration of the declaration documents: Tim Burgess, William Hackett Lifting Products, Alnwick, UK</b>									
A/B	Batch	Lot No / Serial No	Product	Description	Qty	Working Load Limit	Proof Load	Min Breaking Load	
A	P03440	905270261	HN035.SS.163	1.6 Tonne Hackett SS - L5 QP Sub Sea Lever Hoist C/W 3mt HOL, to EN13157	1	1.6 TONNE	2.4 TONNE		
A	P03441	905270449	HN035.SS.323	3.2 Tonne Hackett SS - L5 QP Sub Sea Lever Hoist C/W 3mt HOL, to EN13157	1	3.2 TONNE	4.8 TONNE		
A	P03443	905270484	HN035.SS.633	6.3 Tonne Hackett SS - L5 QP Sub Sea Lever Hoist c/w 3mt HOL, to EN13157	1	6.3 TONNE	9.45 TONNE		



# DNV-GL Salt Water Immersion Testing

Project name:	Sub-sea lever hoist type SS-L5	DNV GL UK Ltd, Oil & Gas
Report title:	Salt Water Immersion Tests	Aberdeen Offshore Services
Customer:	William Hackett Lifting Products United Kingdom,	Cromarty House 67-72, Regent Quay Aberdeen AB11 5AR Tel: +44 (0)1224 335000 Company Registration No. 9208322

Customer contact: Rod Bell, Sales and Operations Director  
 Date of issue: 2017-02-01  
 Project No.: A0359376  
 Organisation unit: Aberdeen Product Certification Survey  
 Report No.: A0359376.02, Rev. 1

Applicable contract(s) governing the provision of this Report:  
 DNV GL Short Form Agreement No. A0359376.01, dated 22<sup>nd</sup> December 2016

## Objective:

Salt Water Immersion Testing of Subsea Lever Hoists in support of a service period duration underwater of:

- 21 day single immersion policy
- 31 day multi immersion policy

## Prepared by:



for DNV GL UK Ltd  
 This document has been digitally signed and will therefore not have handwritten signatures  
 Lines, William  
 Surveyor

William Lines  
 Principal Surveyor

## Verified by:



for Det Norske Veritas AS  
 This document has been digitally signed and will therefore not have handwritten signatures  
 Manson, Stuart  
 Head of Section OBGG 354

Stuart Manson  
 Head of Section, Product Certification  
 Survey

## Approved by:



for DNV GL UK Ltd.  
 This document has been digitally signed and is therefore not have handwritten signatures  
 Doig, Alex  
 Head of Section

Alex Doig  
 Head of Section, Offshore Equipment and  
 Structures

Copyright © DNV GL 2017. All rights reserved. Unless otherwise agreed in writing: (i) This publication or parts thereof may not be copied, reproduced or transmitted in any form, or by any means, whether digitally or otherwise; (ii) The content of this publication shall be kept confidential by the customer; (iii) No third party may rely on its contents; and (iv) DNV GL undertakes no duty of care toward any third party. Reference to part of this publication which may lead to misinterpretation is prohibited. DNV GL and the Horizon Graphic are trademarks of DNV GL AS.

## DNV GL Distribution:

- Unrestricted distribution (internal and external)
- Unrestricted distribution within DNV GL Group
- Unrestricted distribution within DNV GL contracting party
- No distribution (confidential)

## Keywords:

Lever Hoist, Subsea, Salt Water, Testing,  
 Light Load, Corrosion, Operation.

Rev. No.	Date	Reason for Issue	Prepared by	Verified by	Approved by
0	2017-01-16	Draft issue	W. J. Lines		
1	2017-02-01	Published	W. J. Lines	S. Manson	A. Doig

- William Hackett DNV multi immersion report: confidential BP internal only.
- DNV GL Report Number A0359376.02, Rev. 1 – www.dnvgl.com