

# TCS-980 AIR HOIST

The **TCS-980** is a 980 kg high speed chain hoist from Red Rooster Lifting. This is part of our air hoist hook suspension range for lifting equipment applications in industry.



**RED ROOSTER  
LIFTING**

RAISING EXPECTATIONS

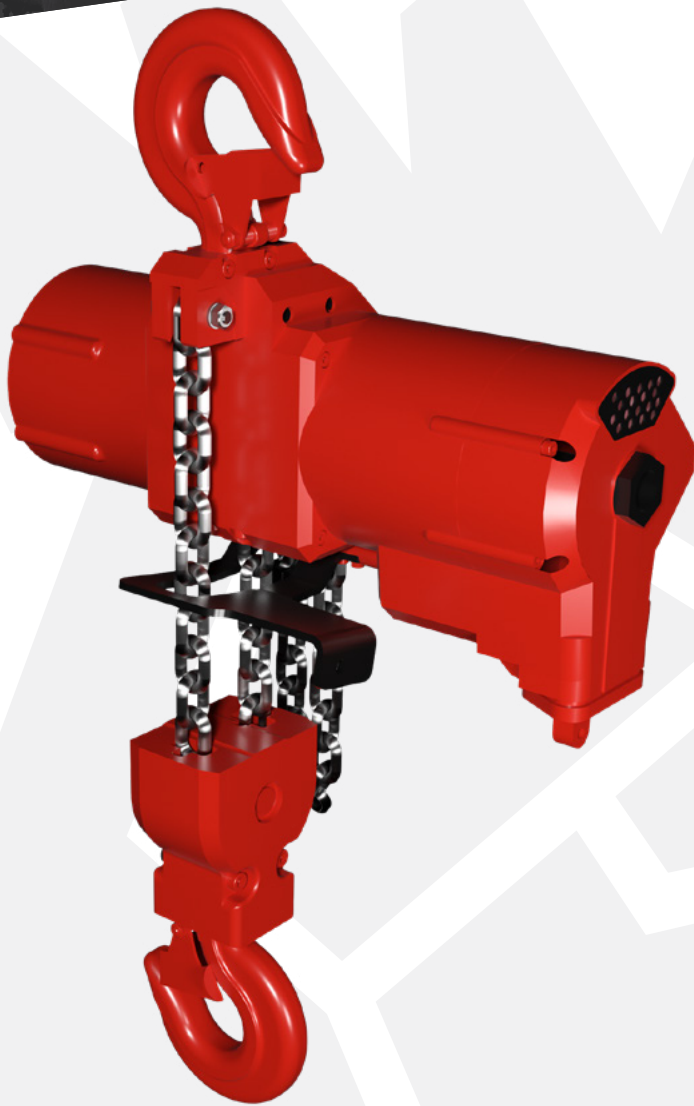

The **Red Rooster Lifting** TCS series of air hoists offers a range of high speed, lightweight lifting equipment suited to all types of industrial and marine environments. Red Rooster Lifting hoists are the perfect lifting solution for where the duty is high, or where a robust hoist is required to withstand harsh conditions. The hoists comply with the UK supply of Machinery (Safety) Regulations 2008 and the European Machinery Directive. The hoists can be UKCA marked or CE marked.

## STANDARD FEATURES

- Lightweight aluminium housing
- Toku rotary vane motor
- Robust epicycle gearbox
- Failsafe automatic internal disc brake
- Mechanical upper & lower switches
- Internal silencing down to 83 dB(A)
- Alloy safety swivel hooks with safety catch
- Load chain 6.3 x 19mm of European manufacture to EN818-7

## AVAILABLE OPTIONS

- Marine specification
- Special paint systems
- Corrosion protection
- UK Ex scheme or ATEX zone 1 specification
- Chain collectors (PVC, galvanised or stainless steel)
- Air Service units
- Radio control
- Main air shut off valve



**UK EX SCHEME ZONE 2  
ATEX ZONE 2  
AS STANDARD**

# TCS-980 AIR HOIST



**RED ROOSTER  
LIFTING**

RAISING EXPECTATIONS

## DIMENSIONS

All measurements are in mm  
Information subject to change without notice

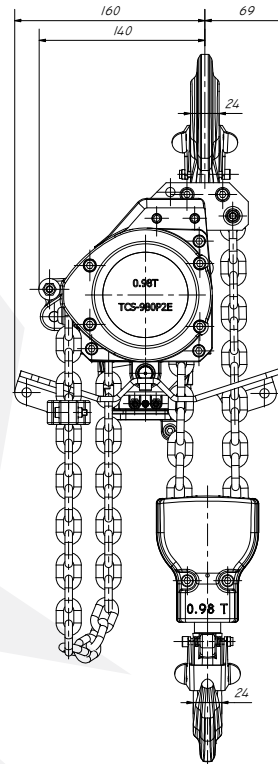
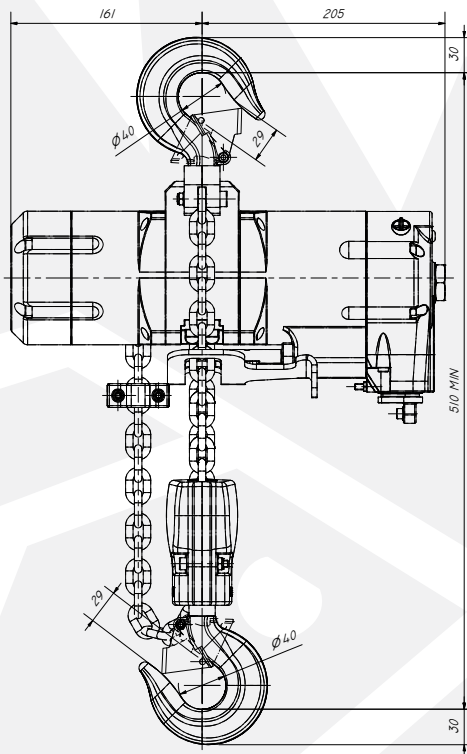

HOIST MODEL	TCS-980
WLL	980 kg
CHAIN FALLS	2
LIFTING SPEED WITH LOAD	8.5 m/min
LIFTING SPEED WITHOUT LOAD	17.0 m/min
LOWERING SPEED WITH LOAD	17.0 m/min
AIR CONSUMPTION LIFTING	28 l/sec
AIR CONSUMPTION LOWERING	33 l/sec
WORKING PRESSURE	6 Bar
AIR CONNECTION	1/2" BSP
MINIMUM HOSE DIA.	1/2"
WEIGHT 3M HOL	23.5 kg
ADDITIONAL METRE HOL	1.6 kg