

Yale[®]

By Columbus McKinnon



BATTERYSTAR

BATTERY POWERED CHAIN HOIST



COMPACT, POWERFUL AND INNOVATIVE

The Yale BatteryStar sets new standards and offers you a unique combination of power, flexibility and mobility that has never been seen before.

The BatteryStar is our first battery-powered chain hoist of its kind that can handle such a high load in such a compact and robust design.

Whether on the construction site, during assembly or at outdoor events - with its load capacity of up to 1,000 kg, the Yale BatteryStar covers the majority of service applications in a wide range of areas.

Time saving and safety:

- Immediate start-up thanks to rechargeable battery
- No wiring and power connection required
- Operation from a safe distance thanks to radio remote control
- Special safety features protect the device against overloading, overheating damage and the weather
- Flexible use of the chain hoist in various positions (standard, as head runner or horizontal)



Horizontal pulling by remote control, also in places without power supply.

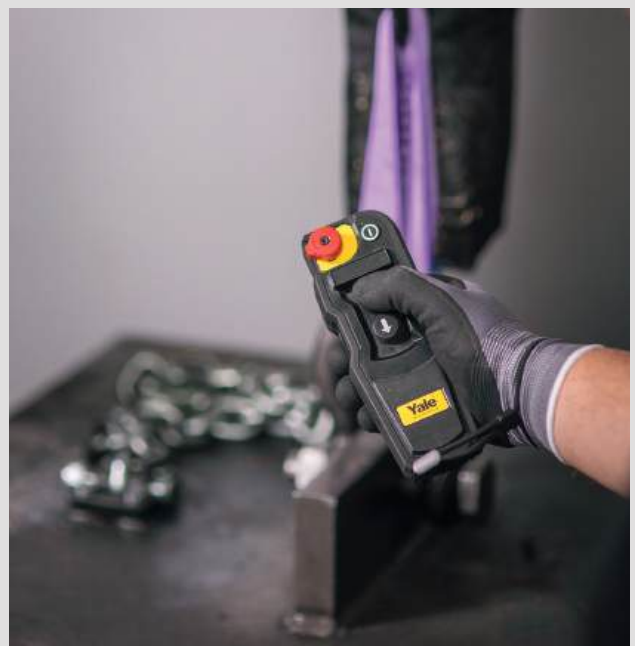

Stepless speed allows precise load positioning.



Compact-size hoist



Battery inside



Wireless control

WHICH HOIST & WHEN

	Hand chain hoist	Yale® BatteryStar™	Power chain hoist
Portability	portable	portable	heavy/stationary
Energy/Power	manual pull power	battery, no cabling	needs cabling for power supply
Cost	low	medium	high
Speed/Efficiency	low	medium	high



Portable hoist for heavy duty lifting.



Outdoor use where power is not available.

FEATURES AND BENEFITS

Capacity: 1.000 kg | **Lift:** 6 m
Lift Speed: 2,4 m/min | Completely wireless | Safe mechanical brake



NO ELECTRIC POWER REQUIRED

- Operates on battery power, specifically a Milwaukee Tool® brand M18™ battery, making it ideal for applications or areas where electricity is unavailable or difficult to reach.
- Provides lifting speeds up to 2.4 m/min, helping increase operator efficiency as much as 4x compared to using a manual hoist.

PORTABILITY

- Weighing 19,8 kg when 6 m of chain is included (less battery), the BatteryStar is compact and lightweight for easy portability.
- Optional road/carrying cases available.



VERSATILE OPERATION

- Hoist can be used in either with the hoist body attached to the anchor point or inverted.
- Inverted operation eliminates the need to carry the weight of the hoist up to the anchor point. Just carry the hook up to the anchor point and let the hoist lift itself and the load up.

DURABILITY & RELIABILITY

- Electronic clutch and secondary mechanical clutch provide dual protection from hoist overload.
- Integrated limit switch for the highest and lowest hook position considerably extends the service life of the slip clutch, motor and gearbox.
- Electronics are IP55 rated.

QUICK & EASY INSTALLATION

- Lightweight and portable, the BatteryStar can be easily attached to an anchor point, then you're ready to lift. No cords or power is required.
- Simply snap a charged battery into place, and the hoist is ready to operate.

PRECISE LIFTING

- Hoist offers true variable speed, allowing for precise lifting and lowering in any application.



PATENT-PENDING BRAKE

- With a patent-pending design, the mechanical brake automatically activates when lowering the load, providing safe operation.
- Brake inspection windows on the top and bottom of the hoist allow operators to easily check brake wear, helping to facilitate preventative maintenance.



TROLLEY OPTIONALLY AVAILABLE

- Convenient and ergonomic transportation of the device, even on uneven terrain.
- Safe storage and protection against damage, moisture and dirt for a long service life of the device and accessories.



SAFE, REMOTE OPERATION

- Remote buttons allow for true variable speed – the further you push the button, the faster the lifting speed. This allows the operator to precisely position the load.
- Wireless remote keeps the operator safe and away from the load, allowing for operation from over 20 m away from the hoist.
- Remote features built-in intelligence, alerting the operator with light-up icons:

-  **Low Battery**
-  **Overcapacity**
-  **Over-Temperature Warning**
-  **Inspection Reminder***

*Hoist inspection light is based on the recommended annual hoist inspection for normal use. Refer to the operator's manual for inspection recommendations by application. Hoist inspection indication requires the use of One-Key™. (see operation manual for details)

FEATURES AND BENEFITS

TRUSTED, HIGH-QUALITY BATTERY

- Supplied battery is fully compatible with more than 250 Milwaukee Tool® products utilizing M18™ batteries for added convenience on the job site.
- Unique patented designs protect every REDLITHIUM™ Battery, safeguarding your investment through drops, weather exposure, and harsh environments.

With the ONE-KEY™ app, you can:

- Define service and inspection intervals
- Activate location services for the device.

The app is available in the App Store® and or Google Play™.



HOOK TRAVEL DISTANCE BY LOAD CAPACITY

- How long the BatteryStar can run on one battery charge depends on the load that is applied on the hoist's hook. The smaller the loads, the longer the hoist can operate without recharging the battery.
- This chart gives you a rough idea of how many meters the BatteryStar can run on one battery charge when loads smaller than 1 tonne are moved.

Battery	Capacity	Hook Travel*
12,0 Ah Akku	250 kg	145 m
	500 kg	90 m
	750 kg	67 m
	1.000 kg	55 m

* Estimated total travel with equal lifting and lowering.

WHAT HAPPENS SHOULD THE BATTERY RUN LOW

This icon on the wireless remote will warn you (slowly flashing red) when the battery has only 25% residual charge when using the recommended 12Ahr battery. Recharge or replace the battery to ensure continued operation.



If the battery runs out of power during operation and the hoist stops operating:

- Simply open the battery compartment and remove the battery, then insert a charged battery.
- Otherwise, in an emergency, open the end compartment and lower the load with a power drill.



PART NUMBERS AND DIMENSIONS

Pos.	Model	Description	Art.-No.	Suspension type hook ¹	Lifting height m	
1	Yale BatteryStar - Basic Kit		1x Yale BatteryStar 1x chain bag 1x remote control	CBCY1008S202	Swivel	6.0
2	Yale BatteryStar - Standard Kit		1x Yale BatteryStar 1x chain bag 1x remote control 1x battery 1x rapid charger	CBCY1008S201EM	Swivel	6.0
3	Yale BatteryStar - Mega Kit		1x Yale BatteryStar 1x chain bag 1x remote control 1x battery 1x rapid charger 1x trolley	192109328	Swivel	6.0

Options

4	Yale BatteryStar - Starter Kit		1x bag 1x beam clamp 2x shackles 2x round slings 2x lifting slings	192109157	
5	Battery (18 V, 12 Ah)			192098606	
6	Rapid charger			192098609	
7	Trolley			192108564	

¹ Rigid hooks on request

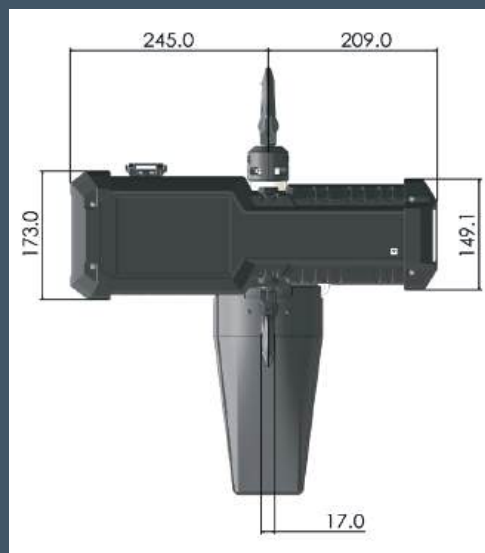
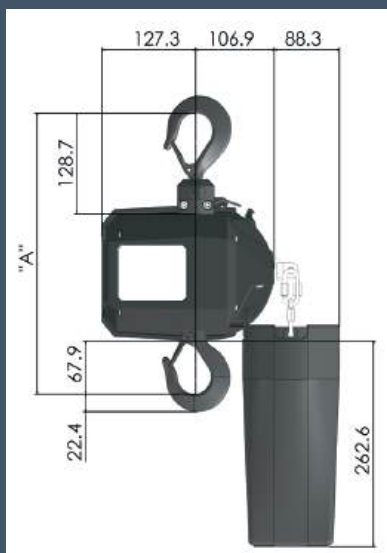

HEADROOM

Hook Type	Dimension „A“ (mm)
Rigid	371
Swivel	401

